

PM-200 POWER SUPPLY MODULE INSTALLATION INSTRUCTIONS

PARTS SUPPLIED WITH THIS KIT:

(1) PM-200 Power Supply Module Circuit Board	(1) 3.6k Ω ¼-Watt Resistor
(8) 1N5408 Diodes	(1) 1 Ω 3-Watt Resistor
(14) 1M Ω ¼-Watt Resistors	(12) 82k Ω 3-Watt Resistors
(6) 180 μ F 450VDC Electrolytic Capacitors	(1) 910 Ω 2-Watt Resistor
(1) 15K Ω ½-Watt Resistor	(1) #20 5" Small Blue Wire

To start the installation, read these instructions very carefully. Unplug the amplifier and remove any input, output and control cables that may be connected to the back of the amplifier. Remove the chassis from the case and remove the perforated sheet metal RF shield from the top of the chassis. Remove the tubes and place them in a safe place. You are now ready to proceed with the installation.

- () Assemble the PM-200 Power Module according to the parts layout diagram. Make sure resistors R1A-R6B are mounted approximately ¼" above the PC board. All other components are mounted flush to the PC board. In addition, solder one end of the 5" #20 **BLUE** wire to the underside of the PC board at pad "V".
- () Place the amplifier on its side (transformer down). Unsolder all wires connected to the power supply circuit board. These are the **RED** and **RED & YELLOW** transformer wires on the top side of the circuit board, a **GRAY** wire and a **YELLOW** wire from the top side of the board (these wires pass through the hole in the circuit board), the **(3) 4.7M Ω resistor assembly** on the bottom of the circuit board and the heavy **BLUE** HV wire on the bottom side of the board.
- () Remove the fixed end of the (3) 4.7M Ω resistor assembly from the terminal strip lug and **discard these resistors**.
- () Remove the (9) #6-32x3/8" screws, washers and nuts that secure the circuit board in place. Save this hardware.
- () Place the amplifier right side up and remove the 5 control knobs from their shafts.
- () Remove the 3 nuts and washers that secure the bandswitch, meter switch and sensitivity potentiometer and save them.
- () Remove the (4) #6-32x3/8" Phillips-head screws, washers and nuts that secure the front panel. Save this hardware.
- () Gently tilt the front panel forward. You may have to carefully pry it loose with a small screwdriver because the paint from the front panel may stick to the chassis. Place the front panel down in front of the chassis.
- () Lift the circuit board from the front so that it tilts upward about 1".
- () Using diagonal cutters, cut the old circuit board from the front left corner all the way back to the wire hole. This will break out a path for the wires to exit. Be careful not to cut any wires during this process. This will free the old circuit board so that it can be removed without further unsoldering of wires.

- () Carefully work the old circuit board out of the compartment and discard it.
- () Take the new circuit board and work it into position with the wires passing through the slot in the board.
- () Secure the board on the right side with 2 or 3 of the #6-32x3/8" screws, washers and nuts. Tighten enough to hold the board. They will be adjusted later.
- () Reinstall the **YELLOW** and **GRAY** wires in their marked holes in the circuit board and solder.
- () Swing the front panel back into position and reinstall the (4) #6-32x3/8" Phillips-head screws, washers and nuts.
- () Reinstall the 3 control flat washers and nuts and tighten.
- () With the amplifier on its side (transformer down), install the remaining #6-32x3/8" screws, washers and nuts holding the circuit board in place. Tighten all screws. You will have one screw left over.
- () Put the **RED** and **RED & YELLOW** transformer wires through their appropriate holes in the circuit board and solder.
- () Place the amplifier upside down.
- () Locate the 2-lug terminal strip just to the rear of the new circuit board. Remove the 15K Ω resistor and clean the holes in the terminal strip lugs. **Note: There is still a blue wire connected to the insulated terminal lug.**
- () Connect the 5" #20 **BLUE** wire connected to hole "V" on the circuit board to the insulated lug of the terminal strip. **DO NOT** solder yet.
- () Connect the supplied 15K Ω 1/2-watt resistor between the 2 lugs of the terminal strip. Solder all connections (See pictorial).
- () Solder the heavy **BLUE** HV wire to the circle pad marked "H" on the underside of the circuit board.
- () Carefully inspect all work. Replace the front panel knobs (make sure they are properly aligned with the front panel markings).
- () Reinstall the tubes and the perforated sheet metal RF shield on the top of the chassis and put the chassis back into the case.

This completes the installation of the PM-200 power supply module. It will provide you with a better power supply that provides the necessary B+ filtering and regulation. Your amplifier should not experience any power supply problems in the future.

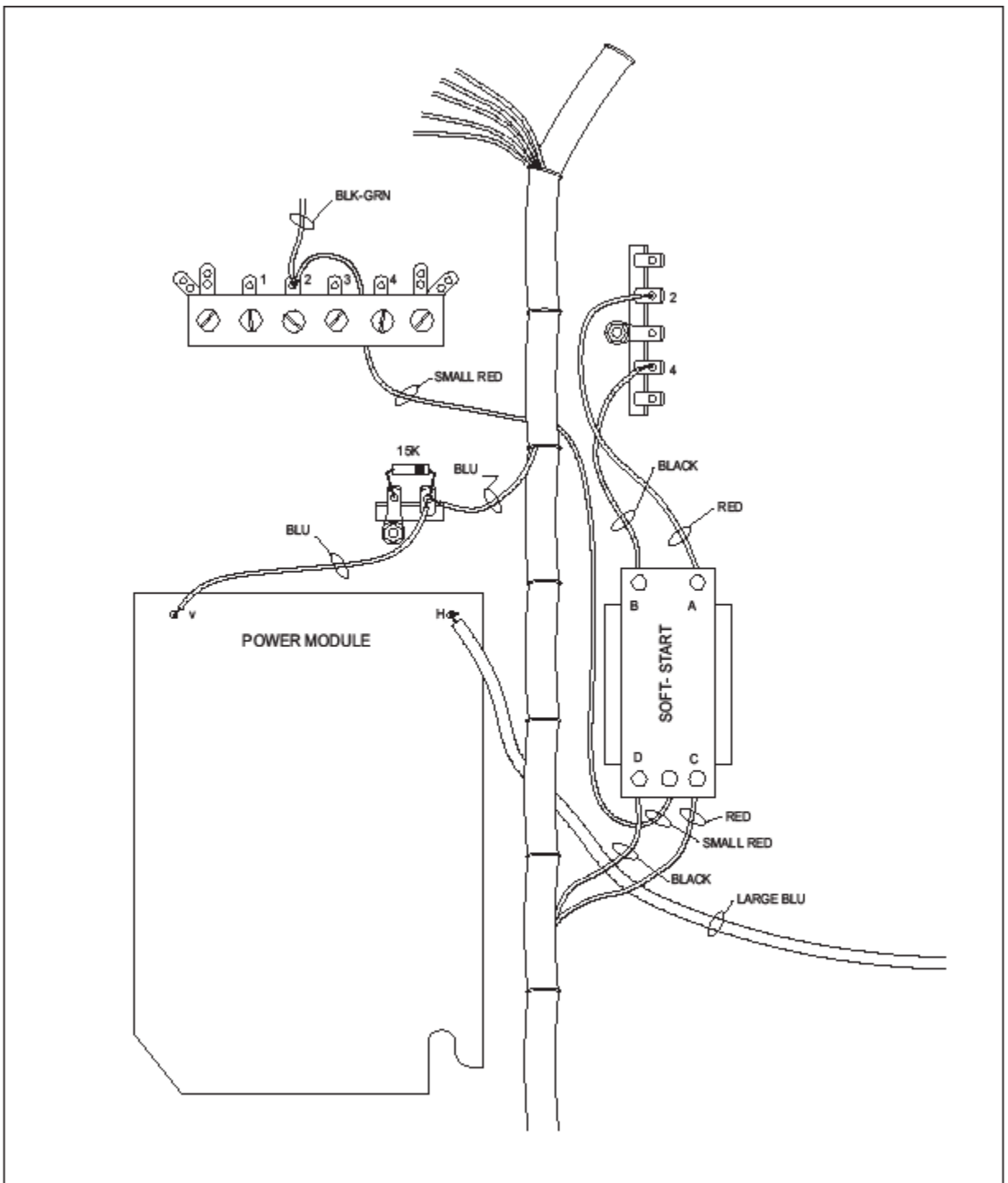

SB 200 POWER MODULE AND SOFT-START
UNDER-CHASSIS WIRING AND PLACEMENT

PC BOARD PARTS DESIGNATION:

C1-C6	180 μ F 450VDC Electrolytic Capacitors	R8	3.6k Ω 1/4-Watt Resistor
D1-D8	1N5408 Diodes	R9	1 Ω 3-Watt Resistor
R1A-R6B	82k Ω 3-Watt Resistors	R11-R24	1M Ω 1/4-Watt Resistors
R7	910 Ω 2-Watt Resistor		

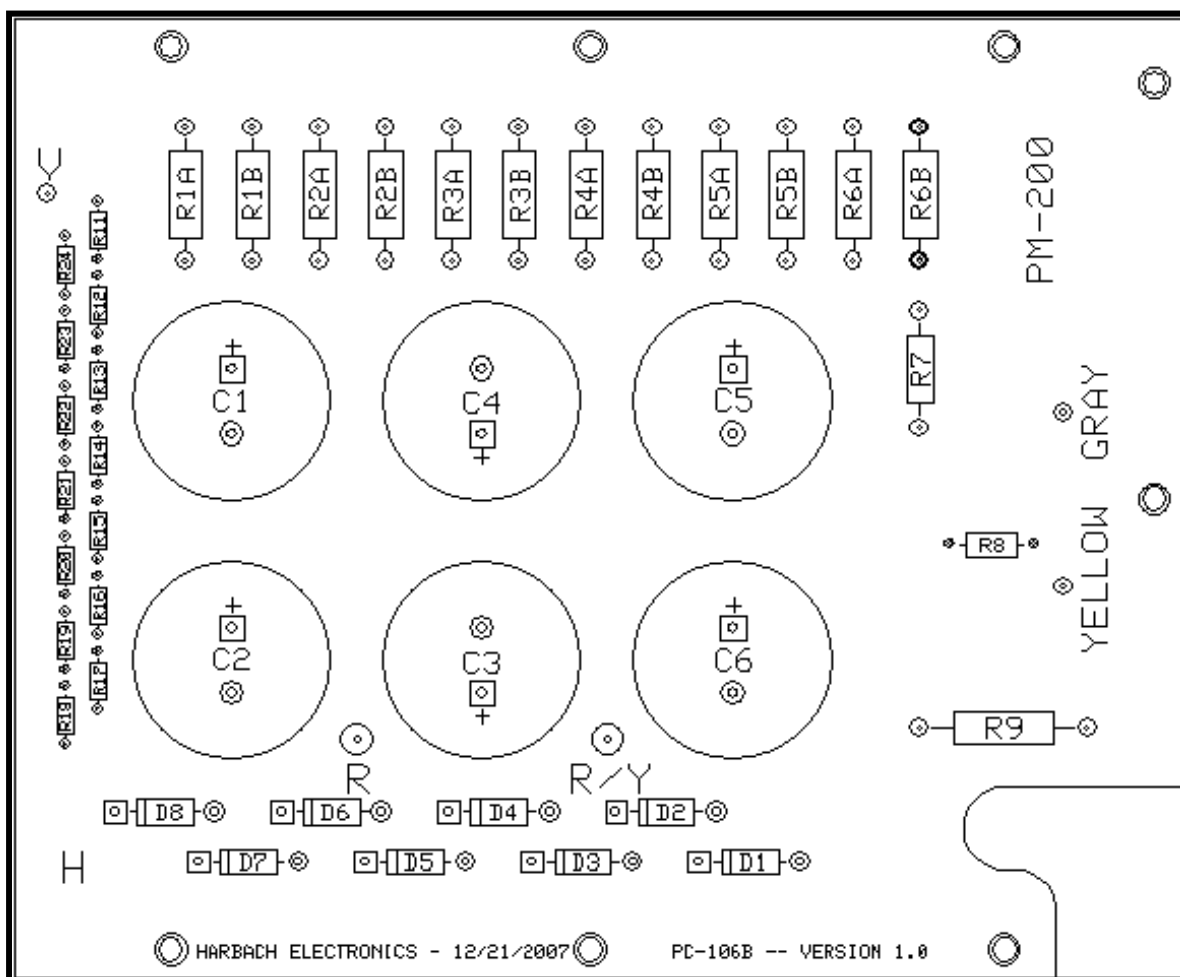

HARBACH ELECTRONICS, LLC

Jeff Weinberg – W8CQ
 468 County Road 620
 Polk, OH 44866-9711
 (419) 945-2359

<http://www.harbachelectronics.com>
info@harbachelectronics.com