

RM-2200 v3.0 RECTIFIER & METERING BOARD INSTALLATION INSTRUCTIONS

PARTS SUPPLIED WITH THIS KIT:

(1) RM-220 v3.0 Rectifier/Metering Circuit Board	(1) 620 Ω 1/2-Watt Resistor
(22) 1N5408 Diodes	(1) 8.87k Ω 1/2-Watt Resistor
(3) 4.7M Ω 1-Watt Resistors	(1) 1 Ω 3-Watt Resistor
(1) 0.82 Ω 3-Watt Resistor	(2) 1/4" x 1/2" Aluminum Hex Spacers
(2) 1/4" x 1/2" Nylon Hex Spacers	(2) #6-32 x 1/4" Steel Screws
(2) #6-32 x 1/4" Nylon Screws	

To start the installation, read these instructions very carefully. Now unplug the amplifier and remove any input, output and control cables that may be connected to the back of the amplifier. Place the amplifier on a book, front panel up, and remove the bottom screws holding the feet and case in place. Lift the case up and remove it from the amplifier. Place the amplifier on the bench with the front panel facing you. You are now ready to proceed with the installation. **NOTE: These are installation instructions for the SB-220/SB-221. They may or may not be exactly the same for the HL-2200!!**

- () Assemble Rectifier/Metering Board according to parts layout diagram.
- () Remove the 15 sheet metal screws that hold the perforated cover in place and remove this along with the top rear plate cover.
- () Remove the 3 large knobs from the front panel.
- () Remove the nut and washer holding the band switch to the front panel.
- () Remove the top rear screw holding the right side panel in place along with the 4 sheet metal screws holding the right side panel.
- () Remove the 2 Phillips-head screws on the right side of the front panel. This will release the right side panel for removal.
- () Remove the 2 Phillips-head screws on the left side of the front panel and loosen the front panel. It may require a slight prying action with a screwdriver to separate the front panel from the chassis due to paint from the front panel sticking to the chassis.
- () Swing the front panel around to the right and support it against the right side of the chassis to prevent undue stress on the wires leading to the panel. Now the old circuit board assembly is fully accessible.
- () Remove the (4) #6-32x1/4" screws holding the old rectifier circuit board to the tapped spacers on the capacitor bank bracket.
- () Swing the circuit board out to gain access to the rear of the board. Unsolder and remove all wires from the board.

- () Cut or unsolder the leads going to the zener bias diode. This is mounted behind and to the left of the old rectifier board. The old zener diode is no longer used. **It is advisable to remove the old zener diode to eliminate possible HV arcing due to dangling leads and dust.**

NOTE: All holes noted in the following steps are marked on the solder side of the new circuit board, and are in a similar location as those on the original rectifier board.

- () Connect the **RED** wire coming from the high voltage transformer to hole “D” on the new circuit board and solder.
- () Connect the **HEAVY BLUE** wire coming from the high voltage feed-through insulator on the left to hole “J” and solder.
- () Connect the **BLUE** wire coming from the bottom of the capacitor bank (the + wire) to hole “H” and solder.
- () Connect the **BLACK** wire coming through the grommited hole in the chassis (from the relay contact) to hole “E” and solder.
- () Connect the **ORANGE** wire coming from the meter switch to hole “G” and solder.
- () Connect the **YELLOW** wire coming from the meter switch to hole “F” and solder.
- () Connect the **BLACK** wire coming from the plate meter to hole “C” and solder.
- () Connect the **RED** wire coming from the plate meter to hole “A” and solder.
- () Connect the **BLACK** wire coming from the top of the capacitor bank (B- wire) to hole “B” and solder.
- () Connect the bare wire of the 0.001 μ F 6KV capacitor to hole “K” and solder.
- () Carefully inspect all solder joints to be sure that both the joint is good and that there are no solder bridges which could short components together. There are very high voltages on this board.
- () Attach the RM-2200 v3.0 circuit board to the side of the capacitor bank shield using the supplied 1/4” x 1/2” aluminum (top mounting holes) and 1/4” x 1/2” nylon (bottom mounting holes) hex spacers and #6-32 x 1/4” steel and nylon screws.
- () Place the front panel back in place and loosely put in the 2 Phillips-head screws on the left side of the front panel.
- () Loosely reinstall the nut and washer holding the band switch to the front panel.
- () Place the right side panel in position and hold it in place with the 4 previously removed sheet metal screws.
- () Reinstall the 2 right side Phillips-head screws in the front panel. Tighten all screws in the front panel and the nut securing the band switch.
- () Reinstall the #6-32 screw, nut and washer on the right rear top of the back panel.

- () Replace the perforated cover and top rear plate cover. Reinstall the 15 sheet metal screws holding these pieces in place. **DO NOT** over tighten these screws, as it is fairly easy to strip the screw threads in the aluminum underneath.
- () Reinstall the 3 large knobs on the front panel. Be sure that your pointer orientation is correct on these knobs.
- () Use the book to hold the amplifier while you reinstall the case and feet.

This completes the installation of the RM-2200 rectifier and metering board. It will provide you with protection from diode failure, as well as providing much more accurate meter readings. When you operate your linear amplifier, you will probably find that the plate voltage reading is much higher than before. This is not really the case. The voltage is the same as before, but you are now reading the true voltage. You may notice a slight reduction in the idling plate current of your HL-2200. This is because the new board produces 6.8V of bias for the 3-500Z tubes, rather than the 5.1V provided by the original Heathkit design. This will lower the heat produced by the amplifier during voice lulls, but will not materially affect the linearity at high power levels.

PC BOARD PARTS DESIGNATION:

D1-D5, D7-1 - D7-8, D8-D12, D15-D18	1N5408 Diode
R1	1Ω 3-Watt Resistor
R2	8.87kΩ ½-Watt Resistor
R3	0.82Ω 3-Watt Resistor
R5	620Ω ½-Watt Resistor
R6-R8	4.7MΩ 1-Watt Resistor

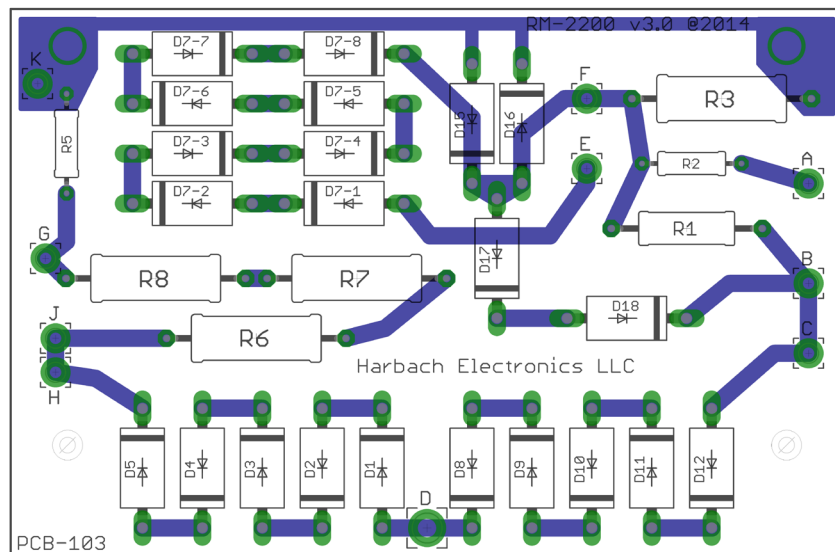

HARBACH ELECTRONICS, LLC

Jeff Weinberg – W8CQ
 468 County Road 620
 Polk, OH 44866-9711
 (419) 945-2359

<http://www.harbachelectronics.com>
info@harbachelectronics.com