

RM-2200 RECTIFIER/METERING BOARD v3.2 ASSEMBLY & INSTALLATION INSTRUCTIONS

WARNING: Voltages inside the amplifier CAN & WILL KILL YOU! You MUST know how to work around HIGH VOLTAGE safely. If you do not, get assistance from someone who does. You MUST also be able to read your specific amplifier schematic and understand the design, theory and wiring of your amplifier to properly perform this upgrade.

NOTE: These are installation instructions for the SB-220/SB-221. They may or may not be exactly the same for the HL-2200!!

RM-2200 RECTIFIER/METERING BOARD ASSEMBLY

- () **Read, re-read and fully understand these instructions prior to beginning this upgrade.** Make sure to perform the steps in the order they are listed. Also, be sure to label wires as they are disconnected from various points inside the amplifier. This will help when the time comes to re-attach the wires that will be disconnected during installation of the kit.
- () Go through the Bill of Materials (BOM) and compare that list with the parts in the kit to make sure all parts are present. If you are missing any parts, please contact Harbach Electronics, LLC.
- () Solder components to the top (silk screened) side of the printed circuit board (PCB) according to parts layout diagram and silk screen on the top of the PCB. All components mount flat to the PCB. Trim the component leads flush on the bottom side of the PCB.

RM-2200 RECTIFIER/METERING BOARD INSTALLATION

- () Unplug the amplifier power cord from the AC mains and let any high voltage stored in the electrolytic capacitors bleed down. Verify the HV has bled down as shown on the HV meter. Remove any input, output and control cables that may be connected to the back of the amplifier.
- () **Be sure that all high voltage has been properly bled to ground before removing any covers or putting your hands inside the amplifier. You CAN BE KILLED by the high voltages inside this equipment!**
- () Place the amplifier on a book, front panel up, and remove the bottom screws holding the feet and case in place. Lift the case up and remove it from the amplifier. Place the amplifier on the bench with the front panel facing you.
- () Remove the 15 sheet metal screws that hold the perforated cover in place and remove this along with the top rear plate cover.
- () Remove the 3 large knobs from the front panel.
- () Remove the nut and washer holding the band switch to the front panel.
- () Remove the top rear screw holding the right side panel in place along with the 4 sheet metal screws holding the right side panel.

- () Remove the 2 Phillips-head screws on the right side of the front panel. This will release the right side panel for removal.
 - () Remove the 2 Phillips-head screws on the left side of the front panel and loosen the front panel. It may require a slight prying action with a screwdriver to separate the front panel from the chassis due to paint from the front panel sticking to the chassis.
 - () Swing the front panel around to the right and support it against the right side of the chassis to prevent undue stress on the wires leading to the panel. Now the old circuit board assembly is fully accessible.
 - () Remove the (4) #6-32x $\frac{1}{4}$ " screws holding the old rectifier circuit board to the tapped spacers on the capacitor bank bracket.
 - () Swing the circuit board out to gain access to the rear of the board. Unsolder and remove all wires from the board.
 - () Cut or unsolder the leads going to the Zener bias diode. This is mounted behind and to the left of the old rectifier board. The old Zener diode is no longer used. **It is advisable to remove the old Zener diode to eliminate possible HV arcing due to dangling leads and dust.**
 - () Connect the **RED** wire coming from the high voltage transformer to hole "D" on the new rectifier/metering PCB and solder. Trim the wire lead on the back side of the PCB if needed.
 - () Connect the **HEAVY BLUE** wire coming from the high voltage feed-through insulator on the left to hole "J" on the new PCB and solder. Trim the wire lead on the back side of the PCB if needed.
 - () Connect the **BLUE** wire coming from the bottom of the capacitor bank (the + wire) to hole "H" on the new PCB and solder. Trim the wire lead on the back side of the PCB if needed.
 - () Connect the **BLACK** wire coming through the grommited hole in the chassis (from the relay contact) to hole "E" on the new PCB and solder. Trim the wire lead on the back side of the PCB if needed.
 - () Connect the **ORANGE** wire coming from the meter switch to hole "G" on the new PCB and solder. Trim the wire lead on the back side of the PCB if needed.
- NOTE: If the original orange wire is too short, use the supplied 10" #22 orange wire to replace the original wire. The original orange wire may be too short as hole "G" on the new circuit board was moved to accommodate the larger 1N5408 diode bias string.
- () Connect the **YELLOW** wire coming from the meter switch to hole "F" on the new PCB and solder. Trim the wire lead on the back side of the PCB if needed.
 - () Connect the **BLACK** wire coming from the plate meter to hole "C" on the new PCB and solder. Trim the wire lead on the back side of the PCB if needed.
 - () Connect the **RED** wire coming from the plate meter to hole "A" on the new PCB and solder. Trim the wire lead on the back side of the PCB if needed.
 - () Connect the **BLACK** wire coming from the top of the capacitor bank (B- wire) to hole "B" on the new PCB and solder. Trim the wire lead on the back side of the PCB if needed.

- () Connect the bare wire of the 0.001 F 6KV capacitor to hole “**K**” on the new PCB and solder. Trim the wire lead on the back side of the PCB if needed.
- () Carefully inspect all solder joints to be sure that both the joint is good and that there are no solder bridges which could short components together. **There are very high voltages on this PCB!**
- () Attach the assembled RM-220 circuit board to the side of the capacitor bank shield using the supplied ¼” x ½” aluminum (top mounting holes) and ¼” x ½” nylon (bottom mounting holes) hex spacers and #6-32 x ¼” steel and nylon screws.
- () Place the front panel back in place and loosely put in the 2 Phillips-head screws on the left side of the front panel.
- () Loosely reinstall the nut and washer holding the band switch to the front panel.
- () Place the right side panel in position and hold it in place with the 4 previously removed sheet metal screws.
- () Reinstall the 2 right side Phillips-head screws in the front panel. Tighten all screws in the front panel and the nut securing the band switch.
- () Reinstall the #6-32 screw, nut and washer on the right rear top of the back panel.
- () Replace the perforated cover and top rear plate cover. Reinstall the 15 sheet metal screws holding these pieces in place. **DO NOT** over tighten these screws, as it is fairly easy to strip the screw threads in the aluminum underneath.
- () Reinstall the 3 large knobs on the front panel. Be sure that your pointer orientation is correct on these knobs.
- () Use the book to hold the amplifier while you reinstall the case and feet.

This completes the installation of the RM-2200 rectifier/metering board. It will provide protection from diode failure, as well as providing much more accurate meter readings. When you operate your linear amplifier, you will probably find that the plate voltage reading is much higher than before. This is not really the case. The voltage is the same as before, but you are now reading the true voltage. You may notice a slight reduction in the idling plate current of your HL-2200. This is because the new board produces approximately 6.8V of bias for the 3-500Z tubes, rather than the 5.1V provided by the original Heathkit design. This will lower the heat produced by the amplifier during voice lulls, but will not materially affect the linearity at high power levels.

RM-2200 RECTIFIER/METERING BOARD PCB PARTS LAYOUT (PCB-103)

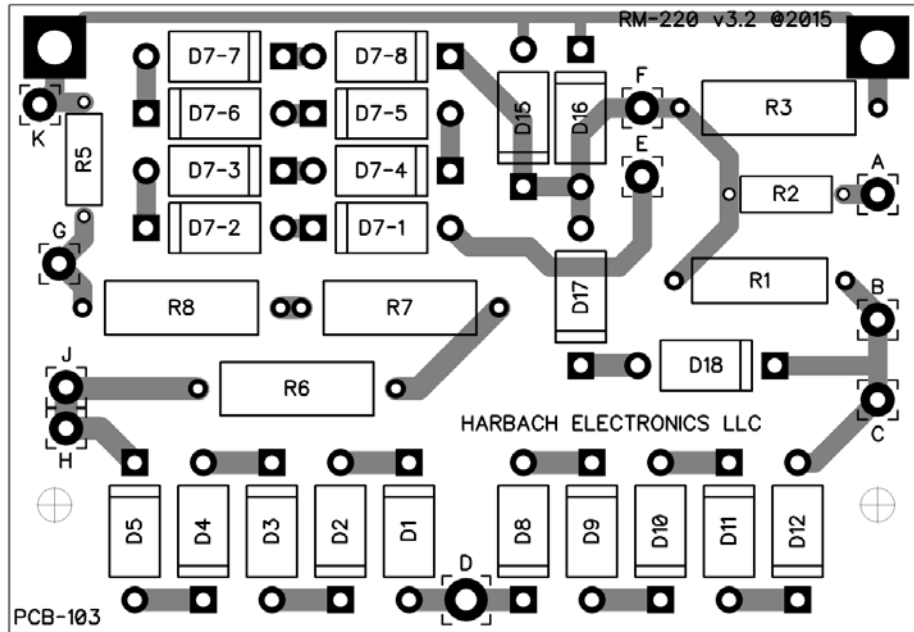

RM-2200 BILL OF MATERIALS (BOM)

Verification	Part Number	Quantity	Description	Designation
[]	PCB-103	1	RM-220 Rectifier/Metering PCB v3.2	N/A
[]	DIO-102	22	3A 1000 PIV Diode (1N5408)	D1-D5, D8-D12, D7-1 – D7-8, D15-D18
[]	RES-152	3	4.7M Ω 1W Resistor	R6-R8
[]	RES-110	1	0.82 Ω 3W Resistor	R3
[]	RES-130	1	620 Ω 1/2W Resistor	R5
[]	RES-131	1	8.87K Ω 1/2W Resistor	R2
[]	RES-109	1	1 Ω 3W Resistor	R1
[]	SCR-105	2	#6-32 x 1/4" Steel Machine Screw	N/A
[]	SCR-400	2	#6-32 x 1/4" Nylon Machine Screw	N/A
[]	SPA-110	2	1/4" x 1/2" Aluminum Hex Spacer	N/A
[]	SPA-111	2	1/4" x 1/2" Nylon Hex Spacer	N/A
[]	WIR-120	10"	#22 Stranded Orange Wire	N/A

HARBACH ELECTRONICS, LLC

Jeff Weinberg – W8CQ
 468 County Road 620
 Polk, OH 44866-9711
 (419) 945-2359

<http://www.harbatchelectronics.com>
info@harbatchelectronics.com