

SK-922 SOFT KEY v3.1

ASSEMBLY & INSTALLATION INSTRUCTIONS

WARNING: Voltages inside the amplifier CAN & WILL KILL YOU! You MUST know how to work around HIGH VOLTAGE safely. If you do not, get assistance from someone who does. You MUST also be able to read your specific amplifier schematic and understand the design, theory and wiring of your amplifier to properly perform this upgrade.

SK-922 SOFT-KEY ASSEMBLY

- () **Read, re-read and fully understand these instructions prior to beginning this upgrade.** Make sure to perform the steps in the order they are listed. Also, be sure to label wires as they are disconnected from various points inside the amplifier. This will help when the time comes to re-attach the wires that will be disconnected during installation of the kit.
- () Go through the Bill of Materials (BOM) and compare that list with the parts in the kit to make sure all parts are present. If you are missing any parts, please contact Harbach Electronics, LLC.
- () Assemble the SK-922 according to the parts layout pictorial (top view of circuit board). There is no right or wrong assembly sequence, just be sure to observe correct polarity of diodes D1-D3 and the correct orientation of Q1-Q2.
- () After assembly, the connection wires can be soldered to the circuit board. Strip approximately ¼" of insulation from both ends of each wire and tin both ends. Solder one end of each wire to the SK-922 as shown on the parts layout pictorial.

SK-922 SOFT-KEY INSTALLATION

- () Unplug the amplifier power cord from the AC mains and let any high voltage stored in the electrolytic capacitors bleed down. Verify the HV has bled down as shown on the HV meter. Remove any input, output and control cables that may be connected to the back of the amplifier.
- () **Be sure that all high voltage has been properly bled to ground before removing any covers or putting your hands inside the amplifier. You CAN BE KILLED by the high voltages inside this equipment!**
- () Remove any input, output and control cables that may be connected to the back of the amplifier. Place the amplifier on towel and remove the bottom screws holding the feet and bottom cover in place. Remove the feet and bottom cover from the amplifier. The preferred mounting location is near the HV transformer in the corner near the side and rear panels. The unit may be mounted in any location using any available method. The easiest method is to mount the SK-922 to a piece of 1-1/2" x 3" fiberglass board or perfboard and then secure the sub-assembly to one of the HV transformer mounting screws. See fiberglass board, SK-922 and sub-assembly mounting details in the drawings included with these instructions.
- () Prepare a 1-1/2" x 3" fiberglass board or perfboard. Drill the SK-922 mounting hole (5/16") and the sub-assembly mounting hole (1/4").

- () Mount the SK-922 unit to the fiberglass board or perfboard using the nylon spacer, #6-32 x ¼” screws and #6 lock washer.
- () Mount the completed SK-922 sub-assembly on to the HV transformer mounting bolt by removing the nut and using any available washers as spacers below the board and then replacing the transformer mounting nut. Note: You may use washers or any available spacers as long as the sub-assembly is above and isolated from the amplifier chassis.
- () Unsolder (or cut very near the solder connection) the **BROWN or GRAY** wire that is connected to the center pin of the antenna relay jack on the back panel.
- () Strip about ¼” of insulation from this wire. Route the end of **BROWN or GRAY** wire that you just disconnected over to the SK-922 circuit board.
- () Solder this **BROWN or GRAY** wire to the wire pad labeled **RLY** on the SK-922 circuit board.
- () Pass the **BLACK** wire from the SK-922 circuit board to the nearest chassis ground connection and solder it to chassis ground.
- () Route the **BLUE** wire from the SK-922 circuit board to the center pin of the antenna relay jack on the rear panel and solder.
- () Route the **RED** wire from the SK-922 circuit board toward the front of the chassis to the 5-lug terminal strip that holds the +110 VDC supply. This terminal strip is located next to the filament transformer along the side panel. Solder this **RED** wire to the terminal where the “+” lead of C3 (33µF 160VDC) and the cathode of D1 (V06E) are attached. See picture below.
- () Replace the bottom cover and feet. Reinstall the screws holding these pieces in place.

This completes the installation of the SK-922 Soft-Key module. You may not **SEE** any difference in the operation of your exciter or amplifier, but you will know that you have reduced the stress on the exciter’s keying relay by many orders of magnitude.

HARBACH ELECTRONICS, LLC

Jeff Weinberg – W8CQ

468 County Road 620

Polk, OH 44866-9711

(419) 945-2359

<http://www.harbachelectronics.com>

info@harbachelectronics.com

SK-922 SOFT-KEY PCB PARTS LAYOUT (PCB-922)

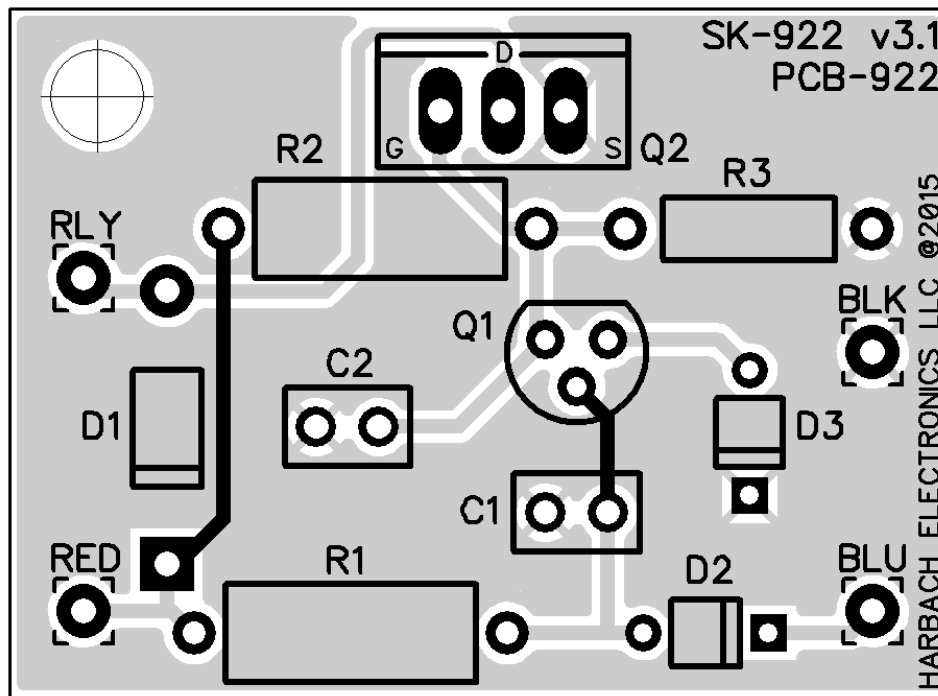

SK-922 BILL OF MATERIALS (BOM)

Verification	Part Number	Quantity	Description	Designation
[]	PCB-103	1	SK-922 Soft-Key PCB v3.1	N/A
[]	CAP-106	2	0.1 μ F 50VDC Capacitor	C1, C2
[]	DIO-101	1	1N4005 Diode	D1
[]	DIO-105	1	1N60A Diode	D2
[]	DIO-106	1	1N4148 Diode	D3
[]	SMI-101	1	PN2222A NPN Transistor	Q1
[]	SMI-102	1	IRF610 N-Channel MOSFET	Q2
[]	RES-116	2	100K Ω 1/2W Resistor	R1, R2
[]	RES-115	1	10K Ω 1/4W Resistor	R3
[]	SCR-105	2	#6-32 x 1/4" Steel Machine Screw	N/A
[]	SPA-102	1	#6-32 1/4" x 3/8" Nylon Hex Spacer	N/A
[]	WAS-105	1	#6 Lock Washer	N/A
[]	WIR-106	8"	#20 Stranded Black Wire	N/A
[]	WIR-107	15"	#22 Stranded Blue Wire	N/A
[]	WIR-108	24"	#22 Stranded Red Wire	N/A

SK-922 MOUNTING BOARD DETAIL

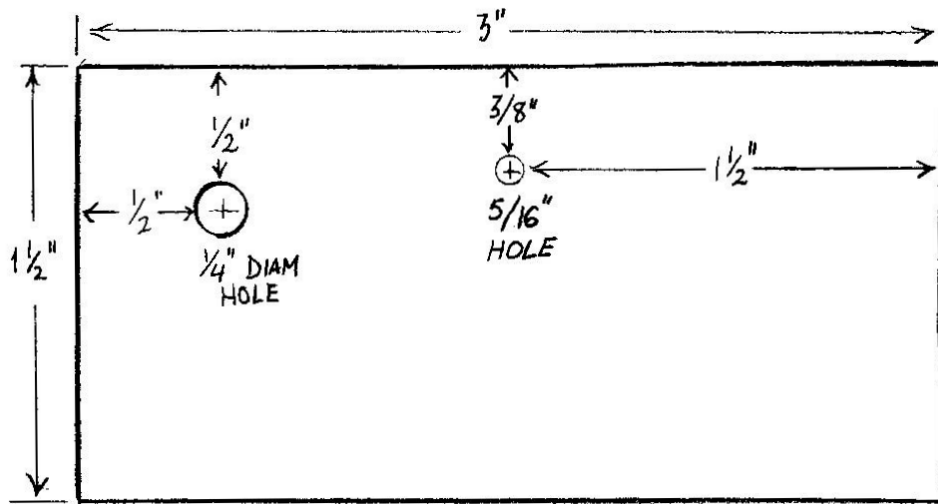

SK-922 SUB-ASSEMBLY MOUNTING DETAIL

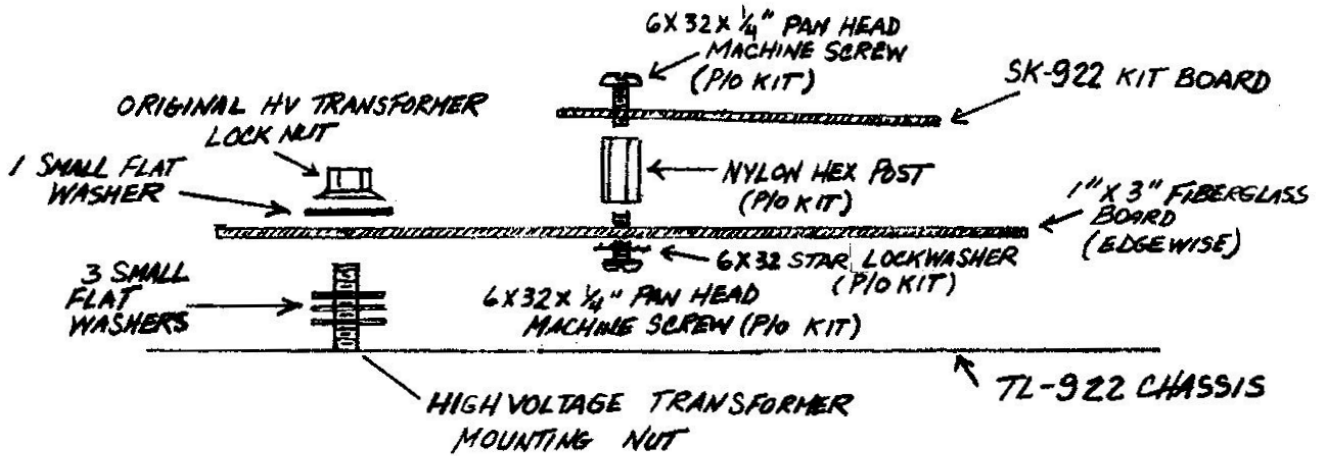

SK-922 MOUNTING LOCATION

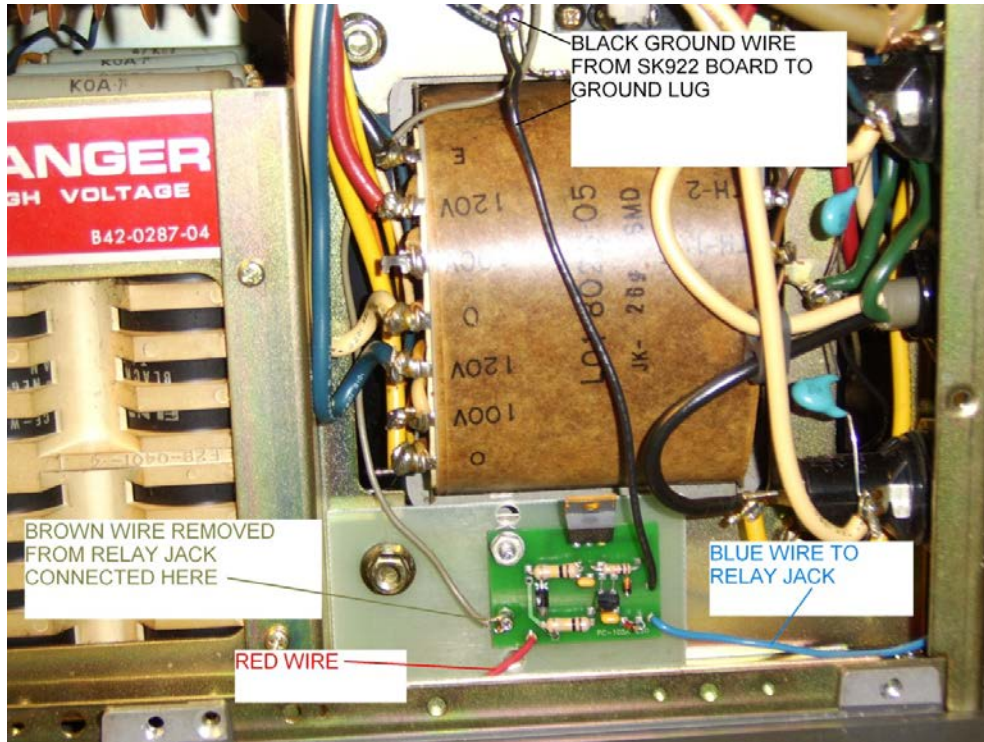

SK-922 +110 VDC HOOKUP

