

SS-100-120 & SS-100-240 UNIVERSAL “SOFT START” MODULE INSTALLATION INSTRUCTIONS

PARTS SUPPLIED WITH THIS KIT:

(1) SS-100 “Soft Start” Circuit Board	(2) 100 μ F 63VDC Electrolytic Capacitors
(2) 48VDC SPDT Relays	(1) 1N4005 Diode
(2) 20 Ω 10-Watt Resistors or (2) 20 Ω 10-Watt Resistors	(1) 2.4k Ω 2-Watt Resistor

It is not possible to give exact installation instructions for the Universal “Soft Start” module because I have neither the schematic nor the physical layout of your specific amplifier or equipment. I can give you enough information, together with the theory of operation of the Universal “Soft Start”, to help you install this module. **NOTE: This module is designed for a typical 120 VAC only or 120/240 VAC dual-primary transformer system.** Installation diagrams for different amplifiers and equipment are available for download from the Harbach Electronics, LLC website.

Please examine the SS-100 module. Note that there are letters on the foil side that designate the leads to be connected. The “C” and “D” leads will be connected to the switched power input. The “A” and “B” leads will be connected to the load. A #20 wire from the hole between pads “C” and “D” (user supplied) is connected to the return (finish lead of the transformer winding) of the input power line (NOT to chassis ground). The module can be mounted using silicone adhesive relay side to the chassis.

The overall operation is quite simple. When the power switch is turned ON, 120 volts is applied to the load through a 10 Ω or 20 Ω 10W resistor in either or both sides of the AC input lines. The voltage at the load is measured by the diode connected to pad “A”. As the filter capacitors and other components charge or stabilize in current drain, the voltage at pad “A” rises. When this voltage reaches approximately 90 volts, the two relays are activated, shorting out the 10 Ω or 20 Ω resistors. Now the power circuit is back to its full power state and the soft start circuit is locked out of operation.

() Assemble the SS-100 according to the parts layout diagram.

If the SS-100 is to be installed in equipment operating from 120 VAC mains (model SS-100-120), the 10 Ω 10-watt resistors will be installed on the PC board. If the SS-100 is to be installed in equipment operating from 240 VAC mains (model SS-201-240), the 20 Ω 10-watt resistors will be installed on the PC board.

INSTALLATION IN A 234/240 VAC 4-WIRE EQUIPMENT OR SYSTEM

If this circuit is to be installed in equipment operating from 234 AC 4-wire mains system, the following connections must be used:

PAD A	One leg of the 234/240 VAC to the load device, usually the transformer primary.
PAD B	One leg of the 234/240 VAC to the load device, usually the transformer primary.
PAD C	One leg of the 234/240 VAC mains supply (usually RED or BLACK).
PAD D	One leg of the 234/240 VAC mains supply (usually RED or BLACK).
PAD F	Connection to the neutral of the 234/40 VAC mains supply (usually WHITE) (NOT GROUND-GREEN).

NOTE: If only one side of the input power line is switched, be sure that the switched lead is on the “C to A” side of the soft start circuit.

PC BOARD PARTS DESIGNATION:

K1-K2	48VDC SPDT Relays	R25-R26	10Ω or 20Ω 10-Watt Resistors
C7-C8	100μF 63 VDC Electrolytic Capacitors	R27	2.4kΩ 2-Watt Resistor
D9	1N4005 Diode		

A #20 wire goes through the hole between pads “C” and “D” and solders to the pad on the foil side of the PC board. This is the return (finish lead of the transformer winding) of the input power line (NOT connected to chassis ground). This is the component-side view.

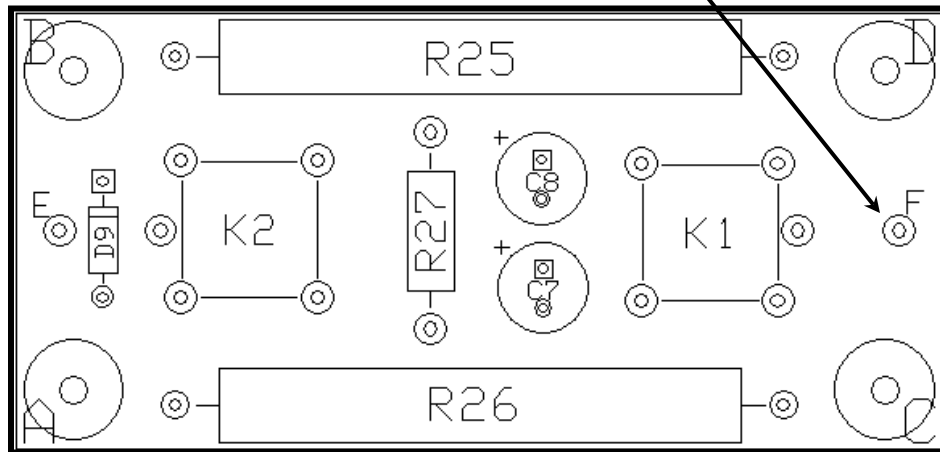

SS-100 SCHEMATIC DIAGRAM

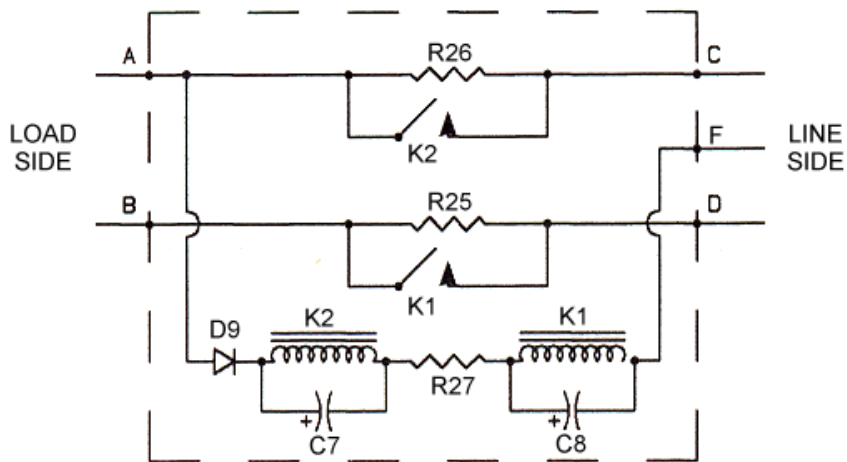

HARBACH ELECTRONICS, LLC

Jeff Weinberg – W8CQ
 468 County Road 620
 Polk, OH 44866-9711
 (419) 945-2359

<http://www.harbatchelectronics.com>
info@harbatchelectronics.com