

SK-201 v3.0 "SOFT KEY" INSTALLATION INSTRUCTIONS

PARTS SUPPLIED WITH THIS KIT:

(1) SK-201 v3.0 Circuit Board	(1) 100 μ F 10VDC Capacitor (C1)	(1) 1N4005 Diode (D1)
(1) 1N5817 Diode (D2)	(1) 1N60(A) Diode (D3)	(1) 4N33 Optocoupler (IC1)
(1) IRF9610 MOSFET (Q1)	(1) 100k Ω 1/2-Watt Resistor (R1)	(1) 10k Ω 1/4-Watt Resistor (R2)
(1) 2k Ω 1/4-Watt Resistor (R3)	(1) Nylon Threaded Spacer	(2) #6-32x1/4" Screws
(1) 2-Lug Terminal Strip	(1) #6 Lock Washer	(1) #20 4" Black Wire
(1) #22 6" Yellow Wire	(1) #22 7" Green Wire	(1) #22 6" Red Wire
(1) #22 8" Blue Wire		

Read these instructions very carefully before any assembly or installation is performed! Be sure to inventory all of the parts in the kit!

- () Assemble SK-201 unit according to the parts layout pictorial (top view of circuit board). There is no right or wrong assembly sequence, just be sure to observe correct polarity of diodes D1-D3, electrolytic capacitor C1, optocoupler IC1 and the correct orientation of Q1.
- () After assembly, the **BLACK, YELLOW, BLUE, RED** and **GREEN** connection wires can be soldered to the circuit board. Strip approximately 1/4" of insulation from both ends of each wire and tin both ends. Solder one end of each wire to the SK-201 as shown on the parts layout pictorial.

Now unplug the amplifier and remove any input, output and control cables that may be connected to the back of the amplifier. Remove the chassis from the case and remove the perforated sheet metal RF shield from the top of the chassis. Remove the tubes and put them in a safe place. You are now ready to proceed with the installation.

- () Turn the amplifier over so that the rear is toward you. Locate a point that is approximately 8" from the right edge of the chassis and approximately 4-1/2" from the rear of the chassis. Mark this point.
- () Very carefully drill a hole that will clear a #6-32 screw at the point you just marked (#27 drill). Do not use too much pressure because you want the drill to stop after just penetrating the chassis. Clean up any burrs from the hole.
- () Rotate the chassis so that it is on its side with the transformer down (it is more stable that way). Push one (1) of the #6-32 screws through the hole from the tube side of the chassis. Put on a lock washer and attach the nylon spacer onto the screw (on the underside of the chassis) and tighten.
- () Inside the tube compartment, locate the screw that fastens the RF shield to the chassis and secures terminal strip "Q" to the underside of the chassis. Terminal strip "Q" is a 5-lug strip mounted at a right angle to the rear of the chassis. Loosen this screw and remove the nut while keeping the screw through the chassis.
- () Place the hold down lug of the supplied 2-lug terminal strip over the end of the #6-32 screw (the one you just removed the nut from). It may require some adjustment of the wiring harness to make room for the strip. The strip should be oriented approximately parallel with the existing terminal strip "Q".
- () Reinstall the #6-32 nut onto the screw and tighten. Now turn the amplifier over (bottom up).
- () Locate the 33 Ω 1-watt resistor going from the antenna relay jack on the rear panel to a solder lug at the end of the primary voltage selection strip. Unsolder the resistor from the jack and move the end so that it goes through the insulated terminal on the 2-lug terminal strip you just installed. **DO NOT** solder yet. Leave the 0.02 μ F disc capacitor connected to the antenna relay jack.
- () Install the SK-201 circuit board on the nylon spacer using a #6-32x1/4" screw. Orient the circuit board with the long side parallel with the rear of the chassis and the IRF9610 MOSFET away from the rear of the chassis.

- () Connect the **BLACK** wire from the SK-201 circuit board to the grounded lug of the 2-lug terminal strip (installed earlier) and solder.
- () Connect the **YELLOW** wire from the SK-201 circuit board to the insulated lug of the 2-lug terminal strip and solder (along with the 33Ω 1-watt resistor).
- () Connect the **BLUE** wire from the SK-201 circuit board to the antenna relay jack on the rear panel and solder (along with the 0.02μF capacitor).
- () On the terminal strip to the left of terminal strip “Q”, locate the junction of the rectifier diode and the 10KΩ 2-watt resistor. Connect the **RED** wire from the SK-201 circuit board to this junction and solder.
- () Fish the **GREEN** wire from the SK-201 circuit board under the capacitor going between terminal strip “Q” and the terminal strip to the left, over the wire bundle and through the grommet in front of the SWR bridge assembly.
- () Rotate the chassis onto its side with the transformer down. Pull the **GREEN** wire all the way through the grommet so that it reaches one of the terminal lugs where the filament choke is soldered. Solder the **GREEN** wire to one of the lugs where the filament choke is attached.
- () Reinstall the tubes and the perforated sheet metal RF shield on the top of the chassis and put the chassis back into the case.

This completes the installation of the SK-201 “Soft Key” module. You may not **SEE** any difference in the operation of your exciter or amplifier, but you will know that you have reduced the stress on the exciter’s keying relay.

PC BOARD PARTS LAYOUT PICTORIAL

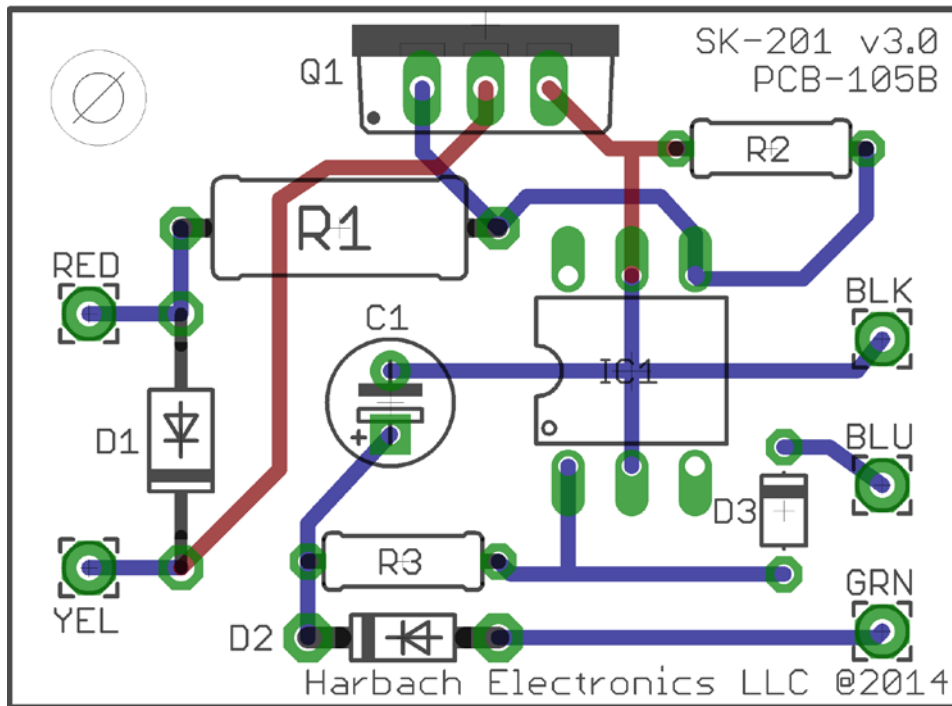

HARBACH ELECTRONICS, LLC

Jeff Weinberg – W8CQ
 468 County Road 620
 Polk, OH 44866-9711
 (419) 945-2359

<http://www.harbachelectronics.com>
info@harbachelectronics.com