

SK-401 v3.0 "SOFT KEY" INSTALLATION INSTRUCTIONS

PARTS SUPPLIED WITH THIS KIT:

(2) 0.1 μ F 50VDC Mono Capacitor (C1-C2)	(1) 1N4005 Diode (D1)
(1) 1N60(A) Diode (D2)	(1) 1N4148 Diode (D3)
(1) PN2222A Transistor (Q1)	(1) IRF610 MOSFET (Q2)
(2) 22k Ω 1/4-Watt Resistors (R1-R2)	(1) 10k Ω 1/4-Watt Resistor (R3)
(1) SK-401 v3.0 Circuit Board	(1) #20 5" Black Wire
(2) #6-32x1/4" Round Head Screws	(1) #20 5" Red Wire
(1) Nylon Threaded Spacer	(1) #22 26" Blue Wire
(1) #6 Internal Tooth Lock Washer	(1) #22 26" Yellow Wire

Read these instructions very carefully before any assembly or installation is performed! Be sure to inventory all of the parts in the kit!

- () Assemble SK-401 unit according to the parts layout pictorial (top view of circuit board). There is no right or wrong assembly sequence, just be sure to observe correct polarity of diodes D1-D3 and the correct orientation of Q1-Q2.
- () After assembly, the connection wires can be soldered to the circuit board. Strip approximately 1/4" of insulation from both ends of each wire and tin both ends. Solder one end of each wire to the SK-401 as shown on the parts layout pictorial.

Now unplug the amplifier and remove any input, output and control cables that may be connected to the back of the amplifier. Place the amplifier upside down with the rear panel facing you and remove 6 screws and the bottom cover. You are now ready to proceed with the installation.

- () The exact mounting location of the SK-401 is not too critical. Be sure to keep the **RED** and **BLACK** leads as short as possible. The most convenient place I have found is just behind (or next to, depending on your version of the L-4B RF deck and whether you have the SS-400 installed) the 24 volt supply terminal strip on the right side near the ON-OFF rocker switch. Try to align the unit such that the **BLUE** wire is nearest the wiring harness and the flat part of the large MOSFET transistor is facing the front of the RF deck.
- () Once you have decided on a location, mark a location where the large hole in the SK-401 is. This is where the mounting spacer attaches to the SK-401 and also the location of the hole for the mounting screw. Very carefully drill a hole that will clear a #6-32 screw at the point you just marked (#27 drill). Do not use too much pressure because you want the drill to stop after just penetrating the chassis. Clean up any burrs from the hole.
- () Place the #6 lock washer onto one of the #6-32x1/4" screws and place the screw through the hole you just drilled. Screw the threaded nylon spacer from the SK-401 kit onto the screw and tighten well without stripping the threads in the spacer.
- () Mount the SK-401 circuit board onto the nylon spacer using the other #6-32x1/4" screw. Position the board as previously described.
- () Remove the small diode that is between 1 lug of the antenna relay jack and a small 1-lug terminal strip next to the antenna relay jack. You can discard the diode. Only the **WHITE & BLUE** wire should be connected to the 1-lug terminal after you removed the diode.
- () Route the **BLUE** and **YELLOW** wires from the SK-401 along (or in) the wiring harness so that both wires end up near the antenna relay jack.

- () Solder the **YELLOW** wire to the terminal of the 1-lug terminal strip next to the antenna relay jack where the **WHITE & BLUE** wire is connected. This effectively connects these wires together.
- () Solder the **BLUE** wire from the SK-401 to the lug of the antenna relay jack. This wire will be attached where the **BANDED END (CATHODE)** of the diode was unsoldered earlier.
- () Solder the **RED** wire from the SK-401 to the +24VDC lug of the terminal strip near where you mounted the SK-401. This lug has the positive (+) end of an electrolytic capacitor, the cathode (banded) end of a diode and a 2.2KΩ resistor soldered to it.
- () Solder the **BLACK** wire from the SK-401 to a convenient chassis ground. The terminal strip described above **USUALLY** has 1 or 2 ground lugs available for this. One or more lugs are directly connected to ground as they are used for mounting the large terminal strip.
- () Replace the bottom cover and any cabling.

This completes the installation of the SK-401 "Soft Key" module. You may not **SEE** any difference in the operation of your exciter or amplifier, but you will know that you have reduced the stress on the exciter's keying relay or transistor.

PC BOARD PARTS PICTORIAL LAYOUT

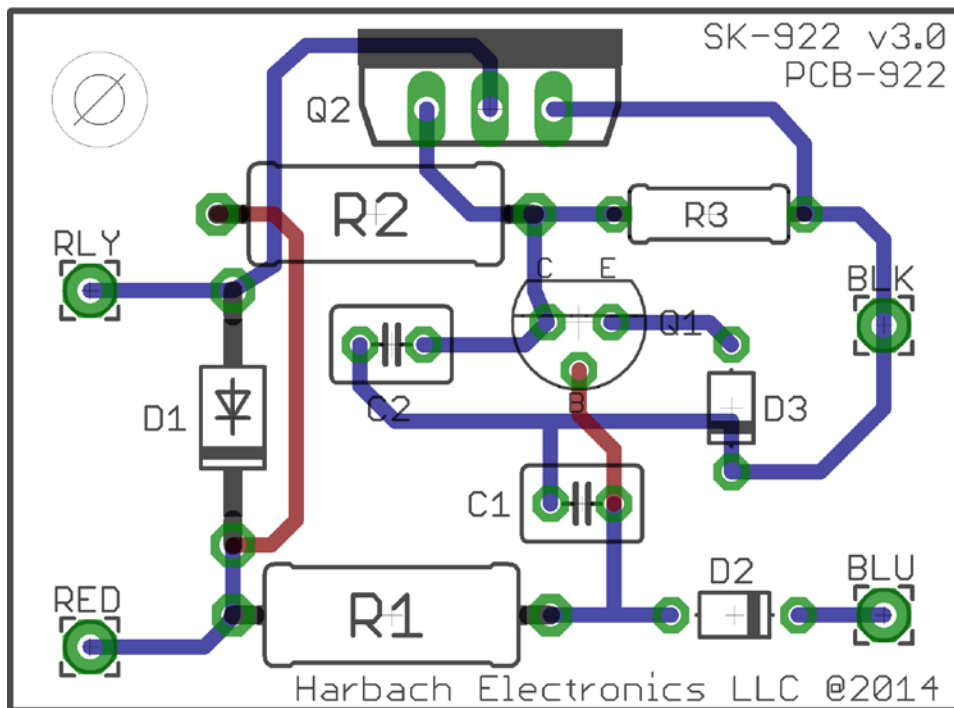

HARBACH ELECTRONICS, LLC

Jeff Weinberg – W8CQ
 468 County Road 620
 Polk, OH 44866-9711
 (419) 945-2359

<http://www.harbachelectronics.com>
info@harbachelectronics.com