

# ES4117-XC POWER SUPPLY MODULE v1.0 ASSEMBLY & INSTALLATION INSTRUCTIONS

ELECTRONIC SPECIALTIES  
53 North 16<sup>th</sup> Street, PO Box 1960  
Fairfield, Iowa 52556  
Phone: 641-472-7084, FAX: 641-472-7620  
Email: [elespe@lisco.com](mailto:elespe@lisco.com)

## PARTS SUPPLIED WITH THIS KIT

- (1) ES4117-XC Circuit Board Assembly v1.0
- (2) 0.01 $\mu$ F 250VAC Safety-Rated Ceramic Disc Capacitors
- (9) Wire Ferrules

**WARNING: Voltages inside the power supply CAN & WILL KILL YOU! You MUST also know how to work around HIGH VOLTAGE safely. If you do not, get assistance from someone who does.**

## PRELIMINARY INFORMATION

Thank you for purchasing the ES4117-XC power supply module for the Swan Electronics 117-X or 117-XC power supply. The module was specifically designed for an easy fit into the 117-X or 117-XC (in a speaker enclosure) power supply from Swan Electronics. The upgraded power supply module replaces all of the original diodes, resistors and capacitors with new upgraded parts pre-installed on a custom PC board. Also provided is the option to select either +600VDC or +900VDC for the final tube high voltage. Some operators prefer the lower voltage to reduce output of the transceiver when driving a linear amplifier and to prolong the life of the transceiver final amplifier tubes.

- ( ) **Read, re-read and fully understand these instructions prior to beginning this upgrade.** Make sure to perform the steps in the order they are listed. Also, be sure to label wires as they are disconnected from various points inside the power supply. This will help when the time comes to re-attach the wires that will be disconnected during installation of the kit.

## TOOLS THAT YOU WILL NEED TO PERFORM THIS UPGRADE

Long nose pliers  
Side cutters, flush cutters, or lead trimmers  
Soldering iron and 60/40 electronic solder  
Schematic of the Swan 117X/XC power supply (A CORRECTED copy is included at the end of the instructions)

## TOOLS THAT WILL BE HELPFUL IN PERFORMING THIS UPGRADE

Desoldering equipment (desoldering braid or vacuum desoldering tool)  
Nut drivers  
Wire strippers  
Forceps or hemostat clamp  
Paper and pencil or digital camera for taking notes and documentation  
Masking tape or wire markers to tag wires during removal of the original PC board

## ES4117-XC POWER SUPPLY MODULE INSTALLATION INSTRUCTIONS

- ( ) Determine the operating status of the power supply before taking things apart. Is the power supply working now? If the supply is not working properly, you need to determine the cause of the problem before installing the kit or the supply may not work properly after installation of the kit.
- ( ) Unplug the AC power cord from the mains outlet and allow time for the high voltage to discharge to 0 VDC.

- ( ) Disconnect the remote power supply cable from the Swan radio.
- ( ) Do not plug in the power cord and re-apply power until you have completed the installation, inspected it and removed any short circuits and stray wire clippings.
- ( ) Remove the cover of the power supply by removing the six (6) screws (three on each side) and lift the cover off. Turn the supply over and remove the four (4) screws securing the bottom cover of the power supply.
- ( ) If you are working with the 117-XC (power supply in a speaker enclosure), remove the cover on the enclosure by removing the six (6) sheet metal screws attaching it to the bottom of the enclosure.
- ( ) If you are working with the 117-X (power supply itself not in a speaker enclosure), remove the cover on the power supply by removing the four screws and lift the cover off.

Before beginning the installation take whatever time is necessary to familiarize yourself with the 117X/XC power supply as built. The connections and wire colors on the new module have been chosen to agree with the original Swan nomenclature in an attempt to eliminate any confusion during installation of the module. Look at the schematic and take the time to trace out the wiring. Make certain that the unit you are going to work on is in agreement with the documentation provided prior to starting the installation. Make the information presented there “your own”. Do not assume or get in a hurry. There is no prize for being fast, only for being right. If something doesn’t look right, contact Electronic Specialties before proceeding. It is much easier to provide assistance before it becomes a pile of loose parts. Manufacturers have been known to deviate from what is generally accepted as “gospel” in the midst of a production run and that can cause problems during installation. Also, old wire colors can be faded and difficult to identify and it can and has happened that the manufacturer changed wire colors during production runs. **Be sure to tag or mark wires as you remove them!**

- ( ) With the 117-X/XC supply resting on the bottom of the chassis with the transformer and power connector to the rear, components inside the supply will be identified according to this orientation.
- ( ) Carefully unsolder or, if necessary clip as close to the PC board as possible, the eight (8) wires connected to the rear (nearest the transformer) of the original PC board. **Be sure to retain as much lead length as possible!**
  - Six (6) transformer leads: RED, RED/GREEN, BLUE, VIOLET, GRAY and WHITE
  - Two (2) RED wires from the HV filter choke that is mounted on the bottom of the chassis below the PC board

NOTE: For the next step, some PC boards had a terminal strip to connect some or all of the following connections while others had some or all of the leads soldered directly to the PC board. If a terminal strip is used don't clip the wires, just remove them from the terminals. If the wires are soldered to the PC board, carefully unsolder them and try not to damage the ends. **Be sure to retain as much lead length as possible!**

- ( ) Remove the following twelve (12) connections from the terminal strip end of the original PC board.
  - Eight (8) wires from the remote cable that connects to the radio: GRAY, ORANGE, YELLOW, WHITE, BLACK, BROWN, GREEN & RED
  - Three (3) connections to the power connector of the power supply: WHITE, BLUE & WHITE/BROWN
  - One (1) WHITE wire connected to a 5 lug terminal strip below the PC board where the AC line bypass capacitors are connected
- ( ) Clip or unsolder the following two (2) connections from the original PC board to the electrolytic capacitors mounted below the PC board on a 3-lug terminal strip.
  - BLUE connected to the positive (+) terminal of the 100µF 350VDC electrolytic capacitor
  - WHITE/RED connected to the negative (-) terminal of the 100µF150VDC electrolytic capacitor
- ( ) Unsolder the BLACK wire from terminal #3 (ground) of the 5-lug terminal strip mounted to the chassis below the original PC board.

- ( ) Remove the original PC board from the chassis by removing the four (4) screws attaching the PC board to the chassis.
- ( ) Remove the two original 100 $\mu$ F electrolytic capacitors and 3-lug terminal strip from the chassis.
- ( ) Replace the two original AC line bypass ceramic disc capacitors connected between terminal #3 (ground) and terminals #4 and #5 of the 5-lug terminal strip mounted to the chassis with the two (2) 0.01 $\mu$ F 250VAC safety-rated ceramic disc capacitors supplied with the kit.
- ( ) Prior to installing the new PC board, select the high voltage you want to operate the transceiver at by soldering the loose end of the red jumper wire to the pad LO (+600VDC) or HI (+900VDC). Insert the wire through the appropriate pad, solder the connection and trim excess lead from bottom side of the PC board.
- ( ) Clean, strip and tin the free end of the transformer and HV choke leads. There should be about 1/4" of tinned wire exposed on each lead.
- ( ) Place the new PC board onto the mounting standoffs with the terminal strip facing up and towards the cable end of the chassis.
- ( ) Connect the transformer leads to the new PC board by inserting the wires into the corresponding solder pads from below the PC board and solder from top of the PC board. After soldering trim any excess lead protruding above the solder cone.
  - RED/GREEN transformer lead to RED-GRN solder pad
  - RED transformer lead to RED solder pad
  - BLUE transformer lead to BLU solder pad
  - VIOLET transformer lead to VIO solder pad
  - WHITE transformer lead to WH solder pad
  - GRAY transformer lead to GRY solder pad
- ( ) Connect the HV choke leads to the new PC board by inserting the wires into the corresponding solder pads from below the PC board and solder from top of the PC board. It does not matter which lead is soldered to which pad. After soldering trim any excess lead protruding above the solder cone.
  - RED filter choke lead to solder pad L1-1
  - RED filter choke lead to solder pad L1-2
- ( ) Raise the new PC board so the terminal block is above the top of the chassis and the terminals are easily accessible.

Due to the age of the power supply wiring (**very fragile**) and the small gauge of wire used by Swan, nine (9) wire ferrules are supplied with the kit to strengthen the wire connection under the pressure plates of the terminal block connectors. The ferrules will be used at positions #1, #2, #3, #6, #7 and #8 on the terminal block. Ferrules are not required on the heavier gauge connections to the terminal block at positions #4 and #5.

Proper preparation for the small wires the connect to positions #1, #2, #3, #6, #7 and #8 on the terminal block is to have approximately 5/16" of tinned wire exposed at the end of each wire and then slip the ferrule over the bare end and pinch gently with long nose pliers to keep the ferrule in place until the wire is connected to the terminal block. **The small gauge wires are very delicate and fragile.** If it is necessary to strip insulation from any of these wire, it is recommended that you "nick" or loosen the insulation with the tip of the soldering iron and **gently** pull the insulation off with your fingers.

- ( ) Connect the following wires from the radio cable to the side of the terminal block facing away from the transformer (nearest the end of the chassis where the remote cable enters). Place the prepared end of the wire beneath the terminal pressure plate and tighten securely except as noted for terminals #1, #2 and #4 where additional connections will be made to the opposite side of the terminal strip. See pictures below.
- RED wire to terminal #8 labeled HV, tighten securely
  - GREEN wire to terminal #7 labeled MV, tighten securely
  - BROWN wire to terminal #6 labeled REL, tighten securely
  - BLACK wire to terminal #5 labeled GND (heavy wire, no ferrule required), tighten securely
  - WHITE wire to terminal #4 labeled FIL (heavy wire, no ferrule required), do not tighten
  - YELLOW wire to terminal #3 labeled BIAS, tighten securely
  - ORANGE wire to terminal #2 labeled SW, do not tighten
  - GRAY wire to terminal #1 labeled SW, do not tighten
- ( ) Connect the following wires from the power connector on the rear of the power supply chassis to the side of terminal strip facing the transformer and rear of the chassis except for the WHITE wire as described below. See pictures below.
- WHITE/BROWN wire to terminal #4 labeled WH/BR (heavy wire, no ferrule required), tighten securely
  - BROWN wire to terminal #2 labeled BR, tighten securely
  - BLUE wire to terminal #1 labeled BU+WH, do not tighten
  - WHITE wire to terminal #1 labeled SW, tighten securely (It will be easier to connect this wire to the other side of the terminal strip as shown in the picture below).

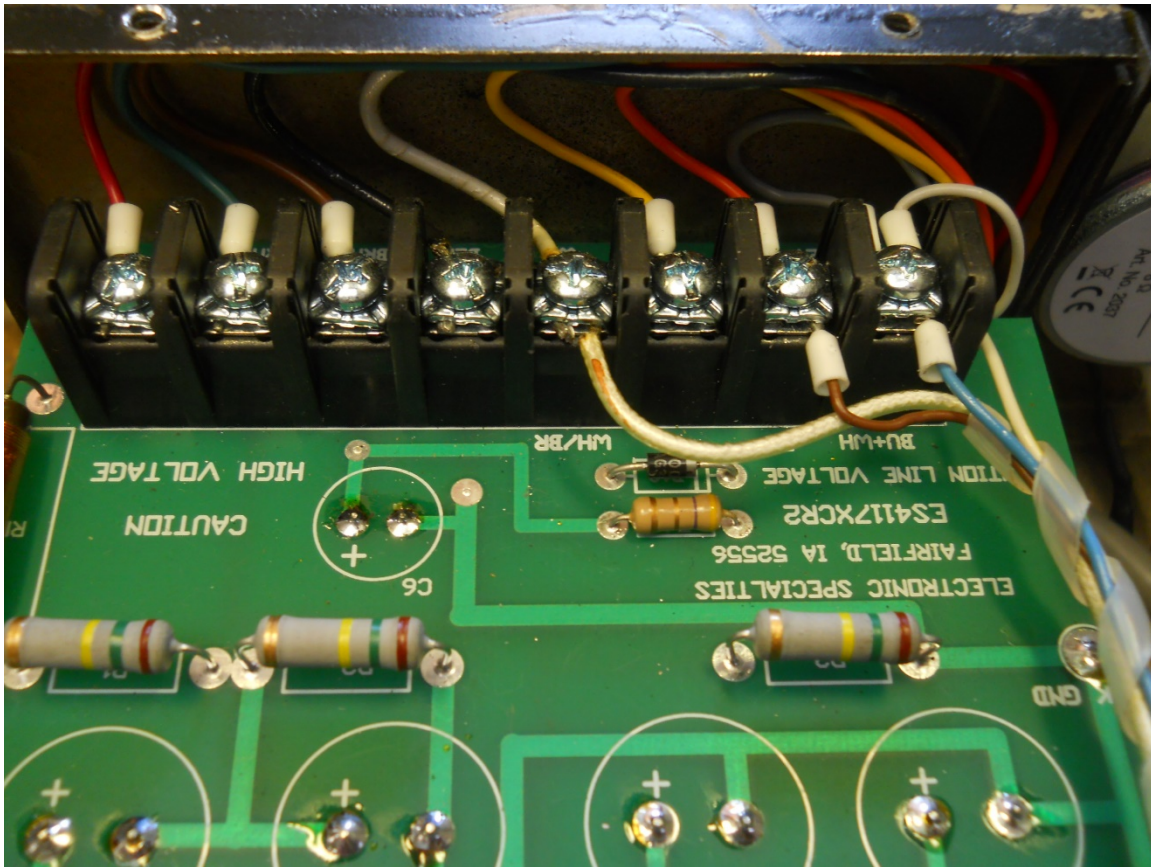



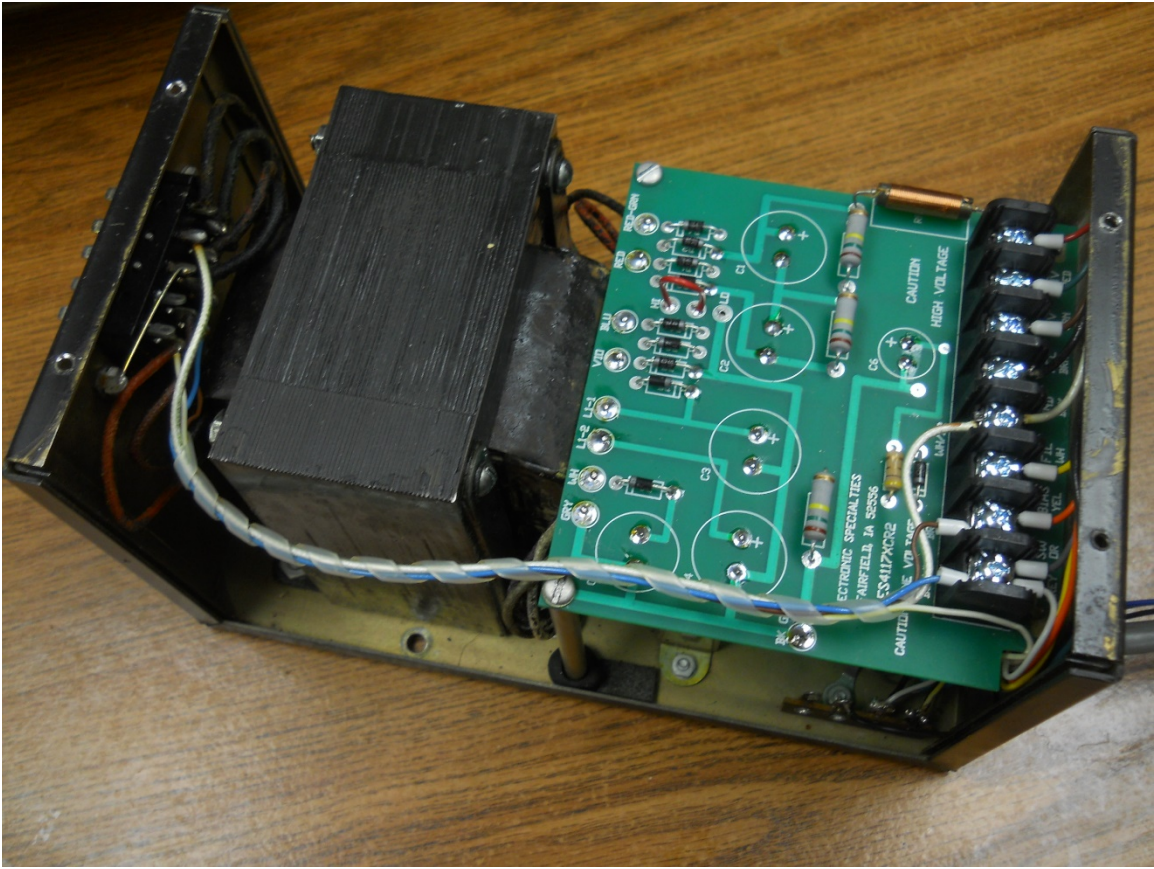

- ( ) Orient the new PC board over its mounting holes and check for proper lead dress to the PC board. Make sure there are no pinched wires at the terminal block end of the PC board.
- ( ) Mount the new PC board to the mounting pillars with the four (4) original mounting screws removed earlier.
- ( ) Solder the BLACK wire from the new PC board to terminal #3 (ground) of the 5-lug terminal strip mounted to the chassis below the new PC board.

That completes the installation of the new ES4117-XC kit into your SWAN 117-X or 117-XC power supply. Be sure to check your work for proper connections and make sure that all wire clippings and any solder splashes are removed from the chassis before proceeding.

## TESTING THE ES4117-XC

### EXERCISE EXTREME CAUTION IN THE FOLLOWING STEPS

**To test the supply, you will need a voltmeter capable of safely measuring 1000 VDC and 500 VAC.**

The power supply can be energized without connecting it to a radio to verify proper operation and measure the no-load voltages. To energize the power supply without a radio connected, place a jumper across position #1 and #2 of the terminal strip on the PC board. This will bypass the ON/OFF switch in the radio. Connect the negative (-) lead of the voltmeter to the power supply chassis. Carefully energize the supply by plugging it into the AC mains power outlet. If there is any sign of a problem, such as a hissing noise or smoke, IMMEDIATELY unplug the supply and determine what the problem is before trying again. Note: These are no-load voltages and they will be higher than when the power supply is connected to a radio. Measurements are referenced to chassis ground unless otherwise noted. **Carefully** probe the following terminal strip connections with the positive (+) lead of the voltmeter. Note: These voltages are approximate and may be higher depending on your AC mains voltage.

Terminal #8 HV	600VDC (LO) or 900VDC (HI)
Terminal #7 MV	300VDC
Terminal #6 RLY	18VDC
Terminal #4 FIL	14VAC
Terminal #3 BIAS	-120VDC

After verifying the proper operation of the power supply unplug the power cord from the AC mains and remove the jumper installed between barrier strip terminals 1 and 2 and replace the cover on the power supply.

The rebuilt 117X or 117XC power supply is now ready for many years of additional service. If you have any questions or comments about the ES4117-XC kit, please don't hesitate to contact me.

Thank you,  
Paul Kraemer, K0UYA

## UPDATED SCHEMATIC FOR THE ES4117X/XC SWAN POWER SUPPLY

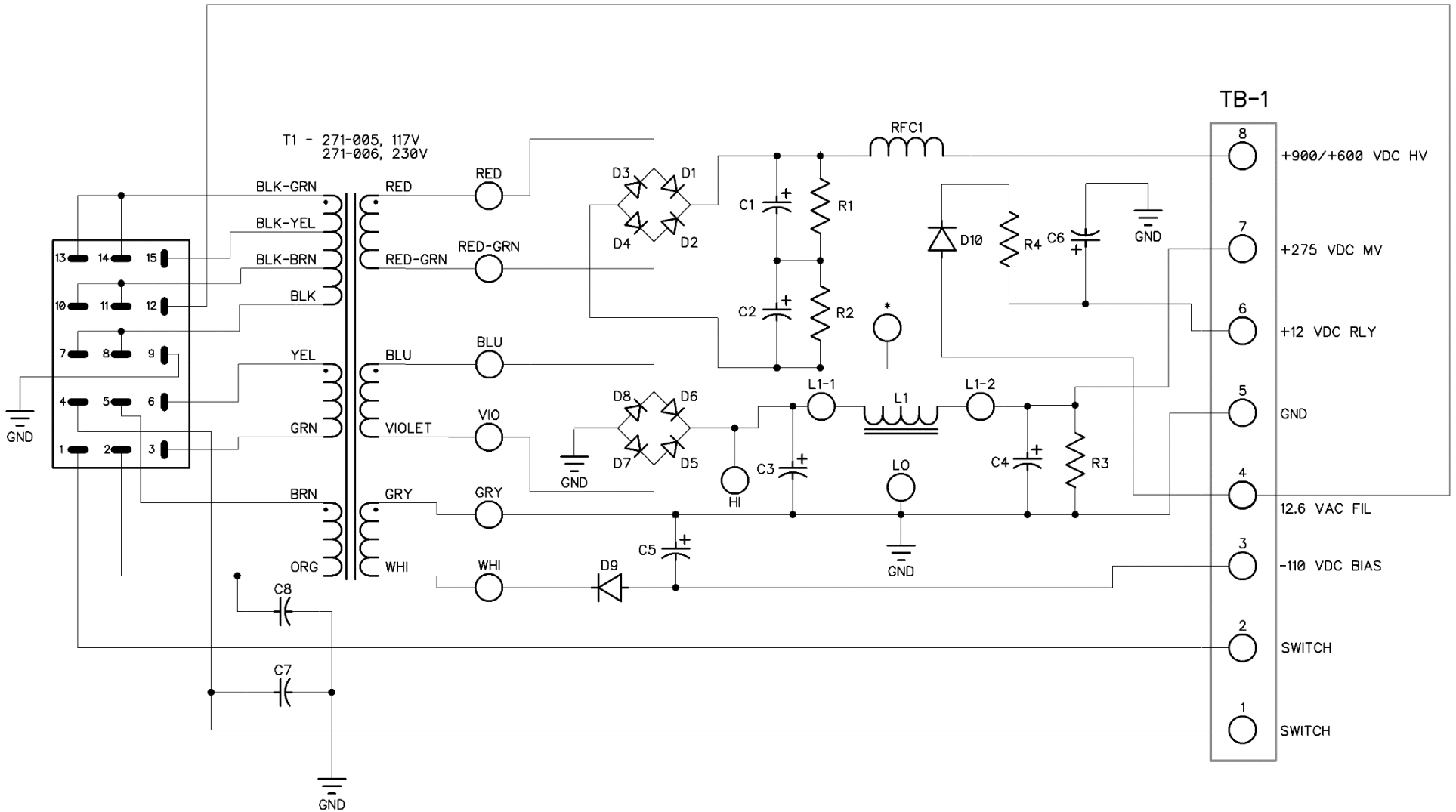

CONNECT "\*" TO "HI" FOR 900VDC HV OR TO "LO" FOR 600VDC HV