

PM-2100F POWER SUPPLY UPGRADE v1.1 ASSEMBLY & INSTALLATION INSTRUCTIONS

WARNING: Voltages inside the amplifier CAN & WILL KILL YOU! You MUST know how to work around HIGH VOLTAGE safely. If you do not, get assistance from someone who does. You MUST also be able to read your specific amplifier schematic and understand the design, theory and wiring of your amplifier to properly perform this upgrade.

PM-2100F POWER SUPPLY UPGRADE ASSEMBLY

- () **Read, re-read and fully understand these instructions prior to beginning this upgrade.** Make sure to perform the steps in the order they are listed. It is also advisable to take a few pictures of the underside of the power supply section for reference. Also, be sure to label wires as they are disconnected from various points inside the amplifier. This will help when the time comes to re-attach the wires that will be disconnected during installation of the kit. This kit uses the same PC boards and parts as the PM-2100B kit; the only difference is in a few of the wiring steps.
- () Go through the Bill of Materials (BOM) and compare that list with the parts in the kit to make sure all parts are present. If you are missing any parts, please contact Harbach Electronics, LLC. Note that the nine (9) turret terminals are pre-installed, staked and soldered to the printed circuit boards (PCBs) and should protrude out from the bottom side of the PCBs.
- () Solder the components to the top and bottom of the PCBs per the parts layout diagram and silk screen on the top and bottom of the PCBs. The electrolytic capacitors C101-103 and C104-C106 mount flush to the top of the PCBs labeled PM-2100B-1 and PM-2100B-2, respectively. Diodes D101-D110 mount flush to the top of the PCB labeled PM-2100B-3. Resistors R111-R113 and R114-R115 mount on the bottom of the PCBs labeled PM-2100B-1 and PM-2100B-2, respectively. **Make sure resistors R111-R115 are spaced approximately ¼” below the bottom of PCBs.** Trim any excess leads from the diodes and resistors after soldering. It is not necessary or advised to trim the leads of the electrolytic capacitors.

PM-2100F POWER SUPPLY UPGRADE INSTALLATION

- () Unplug the amplifier power cord from the AC mains and let any high voltage stored in the electrolytic capacitors bleed down. Verify the HV has bled down as shown on the HV meter. Remove any input, output and control cables that may be connected to the back of the amplifier.
- () **Be sure that all high voltage has been properly bled to ground before removing any covers or putting your hands inside the amplifier. You CAN BE KILLED by the high voltage inside this equipment!**
- () Remove the bottom cover and the remove the outer case from the main chassis. Remove the perforated sheet metal safety shield above the tubes from the top of the chassis. Remove the tubes and place them in a safe place.
- () Place the amplifier on its side with the bottom (underside) of the chassis facing you and the power supply section in the upper right corner.

- () Unsolder the following wires soldered to the rectifier board that is mounted to the chassis between the two capacitor boards.
- One (1) cloth-covered **RED** wire connected to the common end of the two diode strings. The other end of this wire is connected to the 850VAC tap on the power transformer.
 - One (1) cloth-covered **RED** wire connected to the B- end of the top diode string. The other end of this wire is connected to the negative (-) terminal of electrolytic capacitor C106.
 - One (1) solid wire covered with **WHITE** insulation connected to the B+ end of the lower diode string. The wire is a solid piece of bus wire cover with **WHITE** insulating cloth. Remove and save the small piece of **WHITE** insulation covering the wire.
- () Remove the rectifier PCB by removing the two (2) screws used to mount the PCB to the chassis. Save the screws as they will be used to mount the new rectifier PCB in the same location.
- () Unsolder and/or clip the following wires soldered to the upper electrolytic capacitor PCB that is mounted to the chassis. This PCB has electrolytic capacitors C101-C103 mounted on it.
- Two (2) wires covered with **WHITE** insulation connected to the positive (+) terminal of C101. One of these wires is connected to the plate choke and the other was connected to the B+ end of the diode string on the rectifier PCB. Note, the wire connected to the plate choke is also double-insulated with **RED** and **WHITE** inner insulation inside the **WHITE** cloth covering.
 - Two (2) cloth-covered **WHITE** wires connected to the negative (-) terminal of C103. One of these wires is connected to the 0VAC tap on the power transformer (between the 13VAC and 425VAC taps). The other wire is connected to the positive (+) terminal of electrolytic capacitor C104 on the opposite electrolytic capacitor PCB.
- () Unsolder and/or clip the following wires soldered to the lower electrolytic capacitor PCB that is mounted to the chassis. This PCB has electrolytic capacitors C104-C106 mounted on it.
- One (1) cloth-covered **WHITE** wire connected to the positive (+) terminal of C104. The other end of this wires was connected to negative (-) terminal of electrolytic capacitor C103.
 - One (1) **WHITE/BLACK** wire connected to the negative (-) terminal of C106. The other end of this wire is connected to plate current terminal of switch S5 (the plate current/SWR switch).
 - One (1) cloth-covered **RED** wire connected to the negative (-) terminal of C106. The other end of this wires was connected to the B- end of the top diode string.
 - One (1) cloth-covered **RED** wire connected to the negative (-) terminal of C106. The other end of this wires is connected to R3, the plate current meter shunt resistor. **Be very careful when removing this wire as not to damage the meter shunt resistor R3!**
 - The end of resistor R2 (2.2K Ω 1/2W) connected to the negative (-) terminal of C106. The other end of resistor R2 is connected to a single terminal approximately $\frac{3}{4}$ " long marked "T1" located on the bias PCB labeled PB-1903.
 - The end of resistor R1 (220K Ω 2W) connected to the negative (-) terminal of C105. The other end of resistor R1 is connected to a single terminal approximately $\frac{3}{4}$ " long marked "T1" located on the bias PCB labeled PB-1903.
- () Unsolder and/or clip and remove the following wires soldered to terminal "T1" on the bias PCB labeled PB-1903. Note, terminal "T1" is used as a tie point for R2, R1 and a **WHITE/BLUE** wire and has no electrical other electrical connection to any components on the bias PCB.
- The opposite end of resistor R2 (2.2K Ω 1/2W). The other end of resistor R2 was connected to the negative (-) terminal of C106.
 - The opposite end of resistor R1 (220K Ω 2W). The other end of resistor R1 was also connected to the negative (-) terminal of C106.
 - One (1) **WHITE/BLUE** wire.

Once the resistor leads from R1, R2 and the **WHITE/BLUE** wire have been removed from terminal "T1" on the bias PCB, be sure to clean any remaining solder and debris from the terminal so that wires and resistor leads can be reattached later. **DO NOT use too much heat to clean the terminal as this may unsolder it from the bias PCB as the terminal IS NOT staked or mechanically connected to the PCB.**

- Lay the amplifier down flat with the top of the chassis facing up. Remove the four (4) Phillips screws that attach the AC mains voltage selector panel to brackets mounted below the panel.
- Remove the six (6) screws from each electrolytic capacitor PCB (labeled Yaesu P/N PB-1112) using a long Phillips screwdriver. You must move the AC mains voltage selector panel slightly to the left or right to gain access to the screws. Save the screws as they will be used in the next step to install the new electrolytic capacitor PCBs.
- Install the new electrolytic capacitor PCBs marked PM-2100B-1 and PM-2100B-2 using six (6) screws for each board. Electrolytic capacitor board PM-2100B-1 mounts closest to the side of the chassis directly behind the plate current/SWR meter and PCB PM-2100B-2 mounts next to the center divider on the chassis directly behind the plate voltage meter.
- Reinstall the AC mains voltage selector panel back on the support brackets using the original four (4) Phillips screws.
- Place the amplifier back on its side with the bottom (underside) of the chassis facing you and the power supply section in the upper right corner or flat on the top so that the bottom (underside) of the chassis is facing up.
- Remove approximately $\frac{1}{4}$ " - $\frac{1}{2}$ " of **WHITE** cloth insulation along with the **RED** and **WHITE** inner insulation from wire that was removed from the B+ terminal of C101. The other end of this wire is connected to the plate choke. Clean the bare end of the wire and tin. Wrap the tinned end of the wire around the turret terminal marked "**A**" on capacitor PCB PM-2100B-1. Make sure there is a good mechanical connection between the wire end and the turret terminal. **DO NOT** solder yet.
- Make a hook in one end of the supplied #18 solid bus wire. Wrap the hook end of this wire around the turret terminal marked "**A**" on capacitor PCB PM-2100B-1. Make sure that there is a good mechanical connection between the wire and the turret terminal. Solder the two (2) solid wires to terminal turret "**A**" on capacitor PCB PM-2100B-1. Leave the wire standing out of the way. It will be attached in a later step.
- Remove approximately $\frac{1}{4}$ " - $\frac{1}{2}$ " of insulation from the 2 cloth-covered **WHITE** wires that were removed from the negative (-) terminal of C103. Clean the bare end of each wire and tin. Wrap the tinned end of each wire around the turret terminal marked "**B**" on capacitor PCB PM-2100B-1. Make sure there is a good mechanical connection between the wire ends and the turret terminal. Solder both wires to the turret terminal marked "**B**" on capacitor PCB PM-2100B-1.
- Remove approximately $\frac{1}{4}$ " - $\frac{1}{2}$ " of insulation from the cloth-covered **WHITE** wire that was removed from the positive (+) terminal of C104. Clean the bare end of the wire and tin. Wrap the tinned end of the wire around the turret terminal marked "**D**" on capacitor PCB PM-2100B-2. Make sure there is a good mechanical connection between the wire end and the turret terminal. Solder the wire to the turret terminal marked "**D**" on capacitor PCB PM-2100B-2.
- Wrap one end of R1 (220K Ω 2W) around the turret terminal marked "**E**". Make sure that there is a good mechanical connection between the resistor lead and the turret terminal. Solder the resistor lead to the turret terminal marked "**E**".

- () Wrap the other end of R1 (220KΩ 2W) around terminal “T1” on the bias PCB but **DO NOT** solder yet; one or two (2) wraps around the terminal is sufficient. Make sure that there is a good mechanical connection between the resistor lead and terminal “T1”.
- () Remove approximately ¼” - ½” of insulation from the **WHITE/BLUE** wire that was removed from terminal “T1” on the bias PCB in a previous step. Clean the bare end of the wire and tin. Wrap the tinned end of the **WHITE/BLUE** wire around terminal “T1” on the bias PCB but **DO NOT** solder yet; one or two (2) wraps around the terminal is sufficient. Make sure that there is a good mechanical connection between the wire and terminal “T1”.
- () Wrap one end of R2 (2.2KΩ 1/2W) around terminal “T1” on the bias PCB but **DO NOT** solder yet; one or two (2) wraps around the terminal is sufficient. Make sure that there is a good mechanical connection between the resistor lead and terminal “T1”. Solder the lead of R1, the lead of R2 and the **WHITE/BLUE** wire to terminal “T1” on the bias PCB. **DO NOT use too much heat to solder the resistor leads and wire to the terminal as this may unsolder it from the bias PCB as the terminal IS NOT staked or mechanically connected to the PCB.**
- () Make a hook in the free end of R2 (2.2KΩ 1/2W) and wrap it around the turret terminal marked “F” on capacitor PCB PM-2100B-2. Make sure that there is a good mechanical connection between the resistor lead and the turret terminal. **DO NOT** solder yet.
- () Make a hook in the free end of R3 (the plate current meter shunt resistor) and wrap it around the turret terminal marked “F” on capacitor PCB PM-2100B-2. Make sure that there is a good mechanical connection between the resistor lead and the turret terminal. Solder the lead of R2 and the lead of R3 to the turret terminal marked “F” on capacitor PCB PM-2100B-2.
- () Remove approximately ¼” - ½” of insulation from the **WHITE/BLACK** wire that was removed from the negative (-) terminal of C106. Clean the bare end of the wire and tin. Wrap the tinned end of the **WHITE/BLACK** around the turret terminal marked “G” on capacitor PCB PM-2100B-2. Make sure that there is a good mechanical connection between the wire and the turret terminal. **DO NOT** solder yet.
- () Remove approximately ¼” - ½” of insulation from the cloth-covered **RED** wire that was removed from the negative (-) terminal of C106. Clean the bare end of the wire and tin. Wrap the tinned end of the cloth-covered **RED** around the turret terminal marked “G” on capacitor PCB PM-2100B-2. Make sure that there is a good mechanical connection between the wire and the turret terminal. Solder the **WHITE/BLACK** wire and cloth-covered **RED** wire to the turret terminal marked “G” on capacitor PCB PM-2100B-2.
- () Install the new rectifier PCB labeled PM-2100B-3 in the original location on the two (2) phenolic standoffs using the two (2) original screws. The PCB should be mounted such that the turret terminals marked “HVAC”, “B+” and “B-” are visible. The diodes on the PCB will not be visible if the board is installed correctly.
- () Remove approximately ¼” - ½” of insulation from the cloth-covered **RED** wire that was removed from the B- end of the top diode string. The other end of this wire is connected to turret terminal “G”. Clean the bare end of the wire and tin. Wrap the tinned end of the cloth-covered **RED** wire around the turret terminal marked “B-” on rectifier PCB PM-2100B-3. Make sure that there is a good mechanical connection between the wire and the turret terminal. Solder the cloth-covered **RED** wire to the turret terminal marked “B-” rectifier PCB PM-2100B-3.

- Remove approximately 1/4" - 1/2" of insulation from cloth-covered **RED** wire that was connected to the common end of the two diode strings. The other end of this wire is connected to the 850VAC tap on the power transformer. Wrap the tinned end of the cloth-covered **RED** wire around the turret terminal marked "**HVAC**" rectifier PCB PM-2100B-3. Make sure that there is a good mechanical connection between the wire and the turret terminal. Solder the cloth-covered **RED** wire to the turret terminal marked "**HVAC**" rectifier PCB PM-2100B-3.
- Slide the #16 spaghetti tubing and then the **WHITE** insulation that was saved in a previous step over the #18 bus wire. Wrap the free end of this wire around the turret terminal marked "**B+**" on rectifier PCB PM-2100B-3. Make sure that there is a good mechanical connection between the wire and the turret terminal. Solder the #18 wire to the turret terminal marked "**B+**" on rectifier PCB PM-2100B-3.
- Carefully inspect all wiring and solder connections.
- Reinstall the tubes and the perforated sheet metal safety shield above the tubes. Make sure this cover is on correctly as it should open the HV safety interlock when installed correctly. **Note: If the HV interlock is not bypassed (deactivated) by perforated metal safety shield and you turn the amplifier on, the HV supply will short to ground and serious damage will result!**
- Reinstall the outer case and bottom cover onto the main chassis.

This completes the installation of the PM-2100B power supply upgrade. It will provide you with a better power supply that provides the necessary B+ filtering and regulation. Your amplifier should not experience any power supply problems in the future.

PM-2100B BILL OF MATERIALS (BOM)				
Verification	Part Number	Quantity	Description	Designation
[]	PCB-211	1	PM-2100B-1 Capacitor PCB v1.1	N/A
[]	PCB-212	1	PM-2100B-2 Capacitor PCB v1.1	N/A
[]	PCB-213	1	PM-2100B-3 Rectifier PCB v1.1	N/A
[]	CAP-210	6	150µF 500VDC Electrolytic Capacitor	C101-C106
[]	DIO-102	10	3A 1000 PIV Diode (1N5408)	D101-D110
[]	RES-210	6	220KΩ 2W Resistor	R1, R111-R115
[]	RES-211	1	2.2KΩ 1/2W Resistor	R2
[]	TRM-101	9	Solid Turret Terminal	N/A
[]	TUB-160	4.5"	#16 Spaghetti Tubing	N/A
[]	WIR-115	4.5"	#18 Solid Bus Wire	N/A

PM-2100F POWER SUPPLY UPGRADE PCB PARTS LAYOUT (PCB-211 - PCB-213)

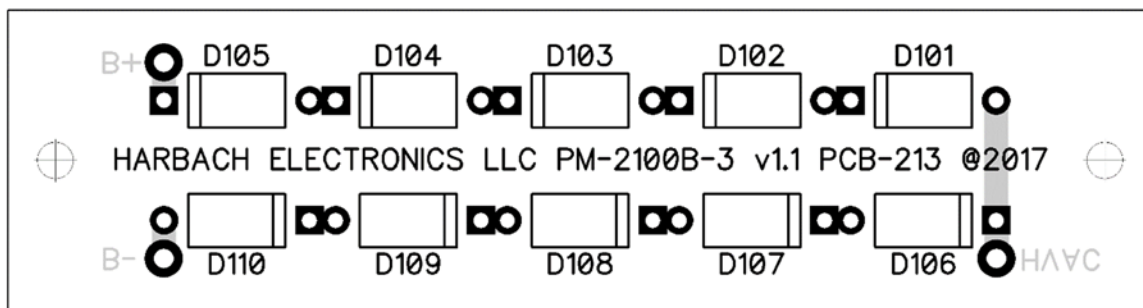
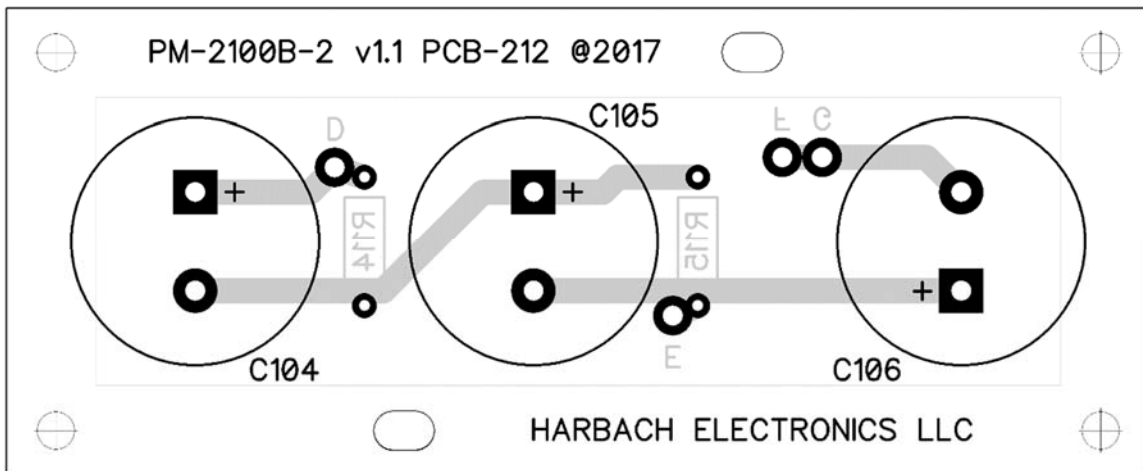
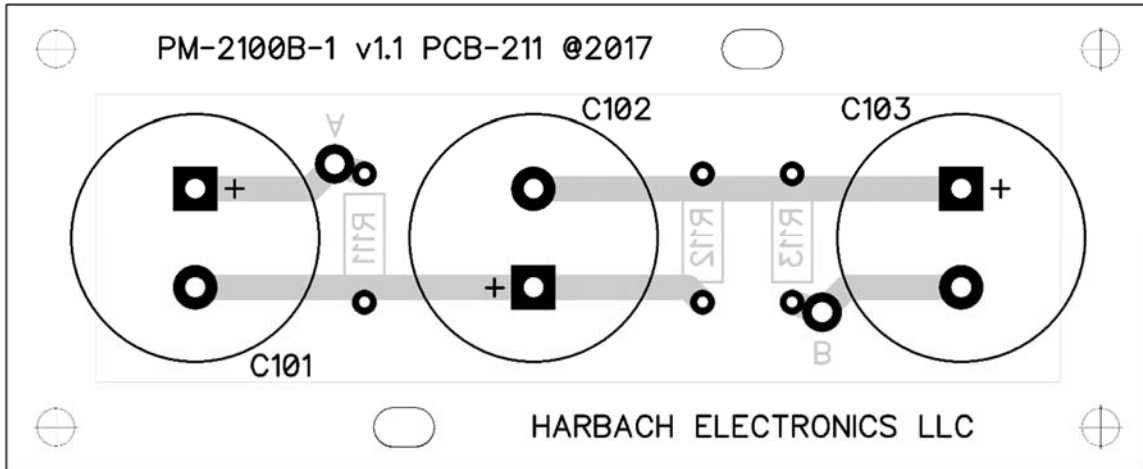

HARBACH ELECTRONICS, LLC
 Jeff Weinberg – W8CQ
 468 County Road 620
 Polk, OH 44866-9711
 (419) 945-2359
<http://www.harbachelectronics.com>
info@harbachelectronics.com