

PM-300 COLLINS 30L-1 REPLACEMENT POWER SUPPLY MODULE v3.1 ASSEMBLY & INSTALLATION INSTRUCTIONS

WARNING: Voltages inside the amplifier CAN & WILL KILL YOU! You MUST know how to work around HIGH VOLTAGE safely. If you do not, get assistance from someone who does. You MUST also be able to read your specific amplifier schematic and understand the design, theory and wiring of your amplifier to properly perform this upgrade.

PM-300 POWER SUPPLY PCB ASSEMBLY

- () **Read, re-read and fully understand these instructions prior to beginning this upgrade.** Make sure to perform the steps in the order they are listed. Also, be sure to label wires as they are disconnected from various points inside the amplifier. This will help when the time comes to re-attach the wires that will be disconnected during installation of the kit.
- () Go through the Bill of Materials (BOM) and compare that list with the parts in the kit to make sure all parts are present. If you are missing any parts, please contact Harbach Electronics, LLC.
- () Solder all diodes and resistors to the silk screened (top) side of the PM-300 printed circuit board (PCB) according to parts layout diagram and silk screen. Trim the leads on the copper trace (bottom) side as necessary. **NOTE: Resistors R2-R6 & R13 (resistors across each capacitor) must be raised above the PM-300 PCB approximately 1/8", but not more than 1/4", above the PCB to allow for proper air circulation and heat dissipation.** This is easily accomplished using a Popsicle stick or similar item as a shim. Remove the shim after each resistor is soldered in place. All other components are soldered flush to the PM-300 PCB.
- () Press the six (6) 220 μ F electrolytic capacitors through the component holes in the PM-300 PCB. The capacitors should be firmly against the PCB. Be certain to observe correct polarity for the capacitors. Solder the capacitors in place and trim the leads on the copper trace (bottom) side of the PM-300 PCB.

PM-300 POWER SUPPLY PCB INSTALLATION

- () Unplug the amplifier power cord from the AC mains and let any high voltage stored in the electrolytic capacitors bleed down. Verify the HV has bled down as shown on the HV meter. Remove any input, output and/or control cables that may be connected to the back of the amplifier.
- () Place the amplifier on a well-lighted work bench. Lift the lid and remove the two countersunk screws that pass through the front panel trim ring. Now close the lid and turn the amplifier over onto a towel or cloth to protect the paint. Remove the 4 feet from the bottom of the cabinet, as well as the additional screw located between the rear feet.
- () Examine the plug on the line cord. It may be necessary to remove the plug from the cord to get the cord out of the cabinet. If this is necessary, note the connection of the wires on the plug on a piece of paper then remove the plug. Turn the amplifier over again and open the lid. Work the amplifier out of the cabinet through the front trim ring. Set the cabinet aside.
- () Place the amplifier on the bench with the left side (power supply side) facing you and the front panel to the right. Remove the cover over the power supply. Observe the shorting interlock ring and verify that it has contacted the shorting screw.

- () Remove two screws from the rear panel that connect the rear panel to the side panel. Now remove all screws from the left side panel and put the panel aside.
- () Unsolder the two (2) 10Ω 2-watt resistors (R17 & R18) from the HV terminal on the dividing partition between the power supply and RF sections of the amplifier.
- () Turn the amplifier over exposing the old rectifier PCB. Remove the four (4) #6-32 pan head screws in the corners of the PCB. Save the screws.
- () Lift the rectifier PCB as clear of the chassis as possible. Remove and save the four (4) spacers. Even though this PCB will not be going back in the chassis, this hardware will be re-used.
- () Unsolder the following six (6) wires attached to the rectifier PCB as follows; a **RED** wire in a **CLEAR** sheath that connects the rectifier and capacitor PCBs together, a **WHITE/BROWN/RED** wire, two (2) **BROWN** wires on a terminal post; a **WHITE/BLACK** ground wire and a **WHITE/RED** wire in the corner of the rectifier PCB.
- () Roll the rectifier PCB over to expose the copper trace (bottom) side. Unsolder the **RED** power transformer secondary wire. The rectifier PCB is now free from the amplifier.
- () As a result of removing the screws securing the rectifier PCB in place, the filter capacitor PCB on the top side of the chassis is now loose. Turn the amplifier back over.
- () Unsolder the **BROWN** wire and the **WHITE/RED** wire from the front corner of the filter capacitor PCB near the center chassis divider. Unsolder and remove the pair of 10Ω 2-watt resistors (R17 & R18) from the filter capacitor PCB and set them aside. Leave the resistors soldered in parallel. They will be reinstalled in the amplifier in a subsequent step.
- () Unsolder the **YELLOW** power transformer secondary wire from the filter capacitor PCB. Unsolder the **RED** wire with **CLEAR** sheath that connects the rectifier PCB and the filter capacitor PCB together. This **RED** wire with **CLEAR** sheath should be free on both ends, pull it out and discard it.
- () Remove the filter capacitor PCB from the amplifier. Remove the four (4) #6-32 screws and four (4) hexagonal standoffs from the old filter capacitor PCB. The old filter capacitor and rectifier PCBs can now be discarded.
- () Fish the **RED** power transformer secondary wire up through the grommet so it is now in the power supply compartment along with the other wires that were unsoldered earlier.
- () Install the four (4) hexagonal standoffs onto the copper trace side (bottom) of the new PM-300 PCB. Tighten the 4 #6-32 screws securely. Now stand the amplifier on its side with the RF deck side down, power supply side and the transformer closest to you.
- () On the top side of the chassis in the wiring harness is a **BROWN** wire that was connected to the old filter capacitor PCB. The other end of this wire is not connected to anything; it was unsoldered in a previous step. You can either pull the unused **BROWN** wire from the wire harness and discard it or clip the ends of the wire and leave it in the harness. **NOTE: The other brown wire unsoldered earlier runs through a wiring harness and connects to the 2nd feed-through capacitor up at the rear of the amp. This is the ALC line and will be connected to the new PM-300 PCB in a later step. Make sure you remove the correct brown wire! Use a VOM to make sure the wire you are going to remove is not the one going to the feed-through capacitor at the rear of the amp.**

In the next steps, all wires will be soldered to the copper trace (bottom) side of the new PM-300 PCB. The R17/R18 resistor pair will be soldered to the silk screened (top) side of the PCB.

- () Clean, prepare and tin the ends of the **RED** and **YELLOW** secondary wires from the power transformer. Solder the **RED** and **YELLOW** secondary wires from the power transformer to the copper trace (bottom) side of the PM-300 PCB in the holes marked **RED XFMR** and **YELLOW XFMR**, respectively. Trim the leads on the silk screened (top) side of the PM-300 PCB as necessary.
- () Solder the remaining **BROWN** wire to the copper trace (bottom) side of the PM-300 PCB at the hole marked **BROWN ALC**. Trim the lead on the silk screened (top) of the PM-300 PCB as necessary.
- () Straighten the wires on the pair of 10Ω 2-watt resistors (R17 & R18) set aside earlier. Insert one end of this resistor pair into the hole on the silk screened (top) side of the PM-300 PCB marked **B+** and solder. Leave the other end free for the moment. Trim the lead on the copper trace (bottom) side of the PM-300 PCB as necessary.
- () Solder the **WHITE/BLACK** wire to the copper trace (bottom) side of the PM-300 PCB at the hole marked **WHITE GND**. Trim the lead on the silk screened (top) side of the PM-300 PCB as necessary.
- () At this point there will be two (2) unconnected **WHITE/RED** wires that were unsoldered earlier; one that was connected to the old rectifier PCB below the chassis and another that was connected to the old filter capacitor PCB above the chassis. These 2 wires are connected together at an unused lug on back of the meter function switch. Route the end of the **WHITE/RED** wire that was connected to the old rectifier PCB below the chassis up through the large hold near the meter switch. Clean, prepare and tin the end of this wire and solder to the copper trace (bottom) of the PM-300 PCB at the hole marked **WHITE/RED B-**. Trim the lead on the silk screened (top) side of the PM-300 PCB as necessary. The other **WHITE/RED** wire can be cut flush and the end insulated with shrink tubing or other suitable insulating material and tucked back out of the way or it can be pulled back to the meter switch, cut off and discarded. **Be careful to cut the correct wire if you choose this method. It is recommended to just cut the wire end flush, insulating and tuck it back out of the way!**
- () Pull some of the **WHITE/BRN/RED** wire from the end that was removed from the old rectifier PCB out of the harness back about 1-1/2" to 2". Pass the free end of this wire up through the chassis and solder to the copper trace (bottom) side of the PM-300 PCB at the hole marked **W/B/R HVM**. Trim the lead on the silk screened (top) side of the PM-300 PCB as necessary.
- () **Review the above steps and compare to the new PM-300 PCB. Carefully examine all solder connections and wire colors. When satisfied, continue.**
- () Carefully insert the PM-300 PCB into position on top of the chassis folding wires underneath as required. The PCB should be positioned so that the four (4) 1MΩ HV metering resistors are near the transformer and the rectifier diodes are near the center chassis partition. Secure in place using the four (4) #6-32 screws and spacers set aside earlier.
- () Solder the top of the R17 & R18 pair to the HV terminal in the center chassis partition.
- () Replace the side cover with five (5) #6-32 screws on the side and two (2) #6-32 screws and washers to join the rear panel to the side cover.
- () Turn the amplifier right side up and set the cabinet on a towel or cloth on the bench behind the chassis. Inspect one more time for loose wires, scraps of wires or other debris. Replace the top cover over the power supply. Secure with five (5) #6-32 round head screws and three (3) #6-32 flat head screws.

- () Feed the line cord through the front bezel then through the appropriate hole in the back of the cabinet. Gently slide the amplifier into the cabinet through the front bezel pulling excess line cord as you go along. Adjust the position of things at the rear panel to allow the fuses and coax connector to pass through their respective holes.
- () Tilt the amplifier on its side with the transformer down and the bottom facing you. Reattach the four (4) rubber feet into their respective holes and secure them. Install the chassis screw between the two rear feet.
- () Set the amplifier on its feet with the front panel facing you. If the plug was removed from the line cord, replace it now.
- () Verify that the **ON/OFF** switch is set to **OFF**.
- () Plug the line cord into an appropriate AC receptacle.
- () Set the **METER** switch to **DC VOLTS**.
- () While observing the meter, turn the **ON/OFF** switch to **ON** for a couple of seconds and then back to **OFF**. The meter should have indicated approximately **2 KV DC**. If it did not, go back and check your work for errors, incorrect wiring, bad solder joints or incorrect polarity on components.

If the meter reading is correct, installation of the PM-300 is complete. The modern diodes and resistors and the fresh electrolytic capacitors should provide clean, stable HV and greatly extend the life of this classic linear amplifier.

PM-300 v3.1 POWER SUPPLY MODULE PCB PARTS LAYOUT (PCB-300)

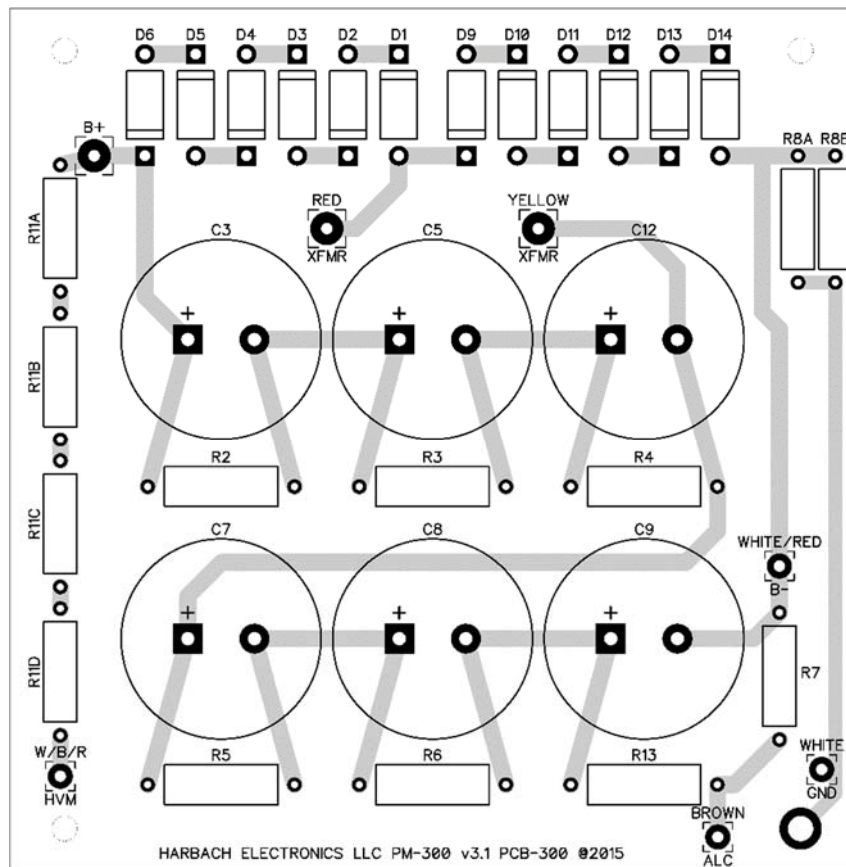

PM-300 v3.1 POWER SUPPLY MODULE SCHEMATIC (PCB-300)

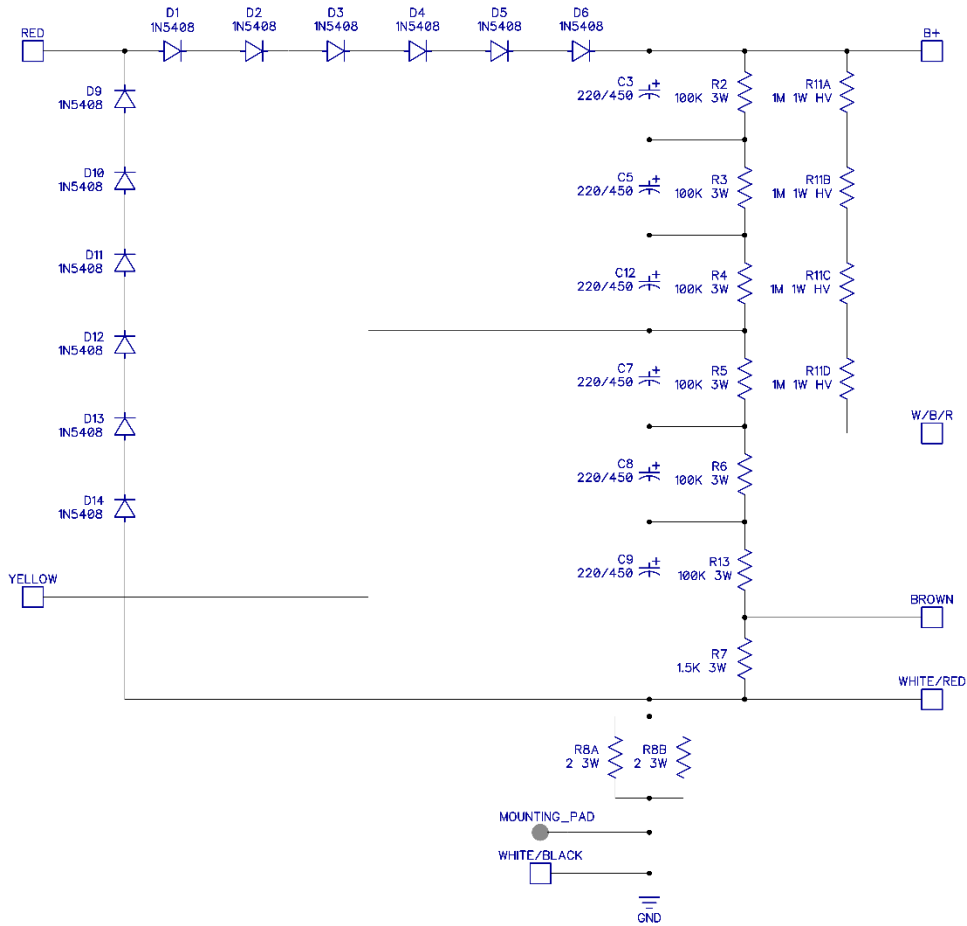

PM-300 v3.1 BILL OF MATERIALS (BOM)

Verification	Part Number	Quantity	Description	Designation
[]	PCB-300	1	PM-300 Power Supply PCB v3.1	N/A
[]	CAP-111	6	220µF 450 VDC Electrolytic Capacitor	C3, C5, C7, C8, C9, C12
[]	DIO-102	12	1N5408 3A 1000 PIV Diode	D1-D6, D9-D14
[]	RES-101	6	100KΩ 3W Resistor	R2-R6, R13
[]	RES-303	1	1.5KΩ 3W Resistor	R7
[]	RES-302	4	1MΩ 1W HV Resistor	R11A-R11D
[]	RES-304	2	2Ω 3W Resistor	R8A, R8B

HARBACH ELECTRONICS, LLC

Jeff Weinberg – W8CQ
 468 County Road 620
 Polk, OH 44866-9711
 (419) 945-2359

<http://www.harbatchelectronics.com>
info@harbatchelectronics.com