

SK-201 SOFT KEY v3.1

ASSEMBLY & INSTALLATION INSTRUCTIONS

WARNING: Voltages inside the amplifier CAN & WILL KILL YOU! You MUST know how to work around HIGH VOLTAGE safely. If you do not, get assistance from someone who does. You MUST also be able to read your specific amplifier schematic and understand the design, theory and wiring of your amplifier to properly perform this upgrade.

SK-201 SOFT-KEY ASSEMBLY

- Read, re-read and fully understand these instructions prior to beginning this upgrade.** Make sure to perform the steps in the order they are listed. Also, be sure to label wires as they are disconnected from various points inside the amplifier. This will help when the time comes to re-attach the wires that will be disconnected during installation of the kit.
- Go through the Bill of Materials (BOM) and compare that list with the parts in the kit to make sure all parts are present. If you are missing any parts, please contact Harbach Electronics, LLC.
- Assemble the SK-201 per the parts layout pictorial (top view of circuit board). There is no right or wrong assembly sequence, just be sure to observe correct polarity of diodes D1-D3, electrolytic capacitors C1 and C2 and the correct orientation of Q1 and VO1.
- After assembly, the connection wires can be soldered to the circuit board. Strip approximately ¼” of insulation from both ends of each wire and tin both ends. Solder one end of each wire to the SK-201 as shown on the parts layout pictorial.

SK-201 SOFT-KEY INSTALLATION

- Unplug the amplifier power cord from the AC mains and let any high voltage stored in the electrolytic capacitors bleed down. Verify the HV has bled down as shown on the HV meter. Remove any input, output and control cables that may be connected to the back of the amplifier. Remove the chassis from the case and remove the perforated sheet metal RF shield from the top of the chassis. Remove the tubes and put them in a safe place. You are now ready to proceed with the installation.
- Turn the amplifier over so that the rear is toward you. Locate a point that is approximately 8” from the right edge of the chassis and approximately 4-½” from the rear of the chassis. Mark this point.
- Very carefully drill a hole that will clear a #6-32 screw at the point you just marked (#27 drill). Do not use too much pressure because you want the drill to stop after just penetrating the chassis. Clean up any burrs from the hole.
- Rotate the chassis so that it is on its side with the transformer down (it is more stable that way). Push one (1) of the #6-32 screws through the hole from the tube side of the chassis. Put on a lock washer and attach the nylon spacer onto the screw (on the underside of the chassis) and tighten.
- Inside the tube compartment, locate the screw that fastens the RF shield to the chassis and secures terminal strip “Q” to the underside of the chassis. Terminal strip “Q” is a 5-lug strip mounted at a right angle to the rear of the chassis. Loosen this screw and remove the nut while keeping the screw through the chassis.
- Place the hold down lug of the supplied 2-lug terminal strip over the end of the #6-32 screw (the one you just removed the nut from). It may require some adjustment of the wiring harness to make room for the strip. The strip should be oriented approximately parallel with the existing terminal strip “Q”.
- Reinstall the #6-32 nut onto the screw and tighten. Now turn the amplifier over (bottom up).

- () Locate the 33Ω 1-watt resistor going from the center conductor of the antenna relay jack on the rear panel to a solder lug at the end of the primary voltage selection strip. Unsolder the resistor from the center conductor of the relay jack and move the end so that it goes through the insulated terminal on the 2-lug terminal strip you just installed. **DO NOT** solder yet. Leave the 0.02μF disc capacitor connected to the center conductor of the antenna relay jack.
- () Install the SK-201 circuit board on the nylon spacer using a #6-32x1/4" screw. Orient the circuit board with the long side parallel with the rear of the chassis and the IRF9610 MOSFET away from the rear of the chassis.
- () Connect the **BLACK** wire from the SK-201 circuit board to the grounded lug of the 2-lug terminal strip (installed earlier) and solder.
- () Connect the **YELLOW** wire from the SK-201 circuit board to the insulated lug of the 2-lug terminal strip and solder along with the 33Ω 1-watt resistor.
- () Connect the **BLUE** wire from the SK-201 circuit board to the center conductor of the antenna relay jack on the rear panel and solder (along with the 0.02μF disc capacitor).
- () For the next two (2) steps, refer to the drawing below.
- () On terminal strip "N", locate the junction of the anode of rectifier diode D17, the negative (-) lead of electrolytic capacitor C3 and one end of 10KΩ 2-watt resistor R2 on lug #5 of terminal strip "N". Connect the **RED** wire from the SK-201 circuit board to lug #5 of terminal strip "N" and solder.
- () Fish the **GREEN** wire from the SK-201 circuit board under electrolytic capacitor C3 connected between terminal strip "Q" and terminal strip "N", under the existing wire bundle and through grommet "P".

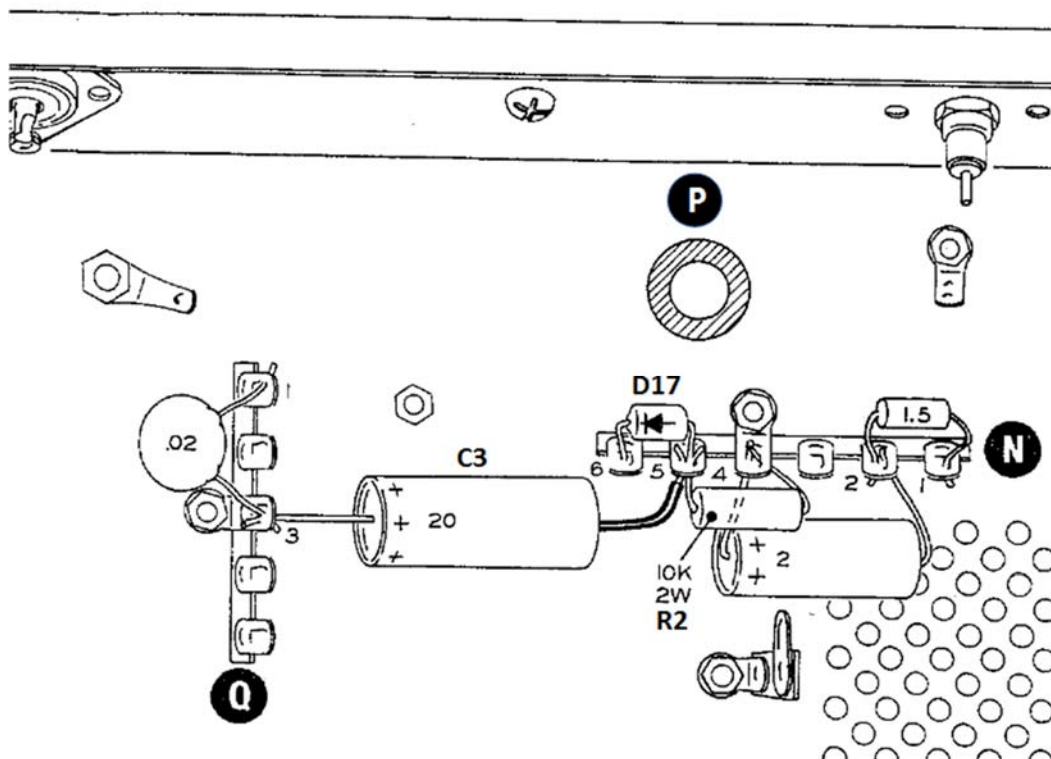

- () Rotate the chassis onto its side with the transformer down. Pull the **GREEN** wire all the way through grommet "P" so that it reaches the 3-lug terminal strip "M". Solder the **GREEN** wire to lug #1 **OR** lug #3 of terminal strip "M", **but not both**. Refer to the drawing below. **Note:** Some late-model SB-200 and SB-201 amplifiers have a 5-lug terminal strip "M". In this case, solder the **GREEN** wire to lug #3 **OR** lug #5 of terminal strip "M", **but not both**

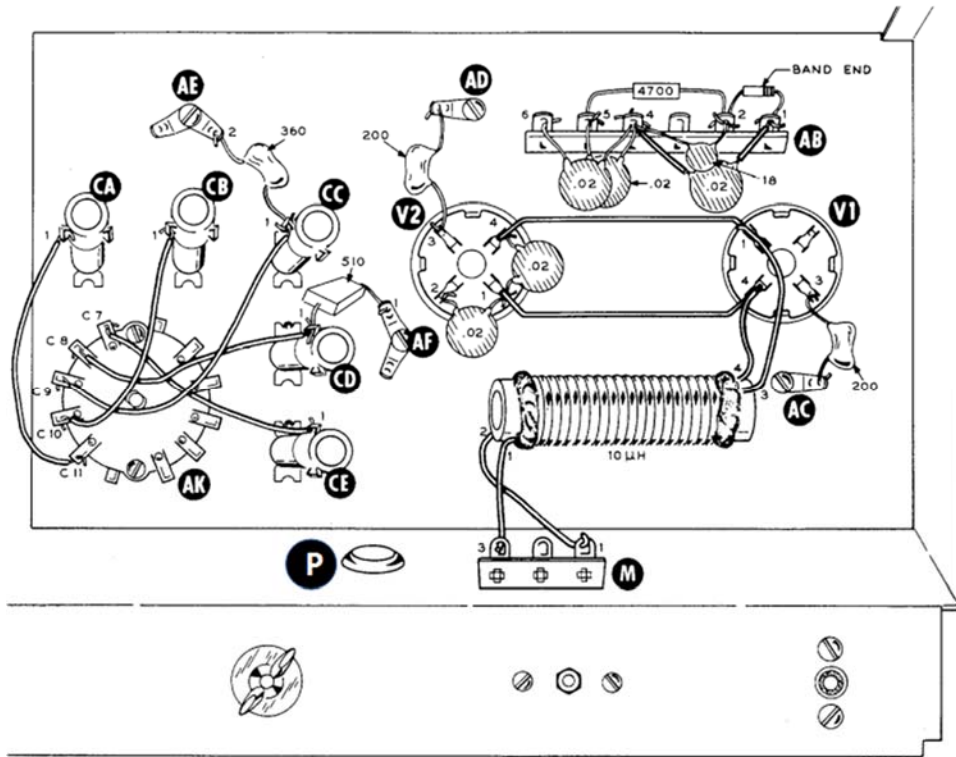

- () Reinstall the tubes and the perforated sheet metal RF shield on the top of the chassis and put the chassis back into the case.

This completes the installation of the SK-201 Soft-Key module. You may not **SEE** any difference in the operation of your exciter or amplifier, but you will know that you have reduced the stress on the exciter's keying circuitry.

SK-201 SOFT-KEY PCB PARTS LAYOUT (PCB-105B)

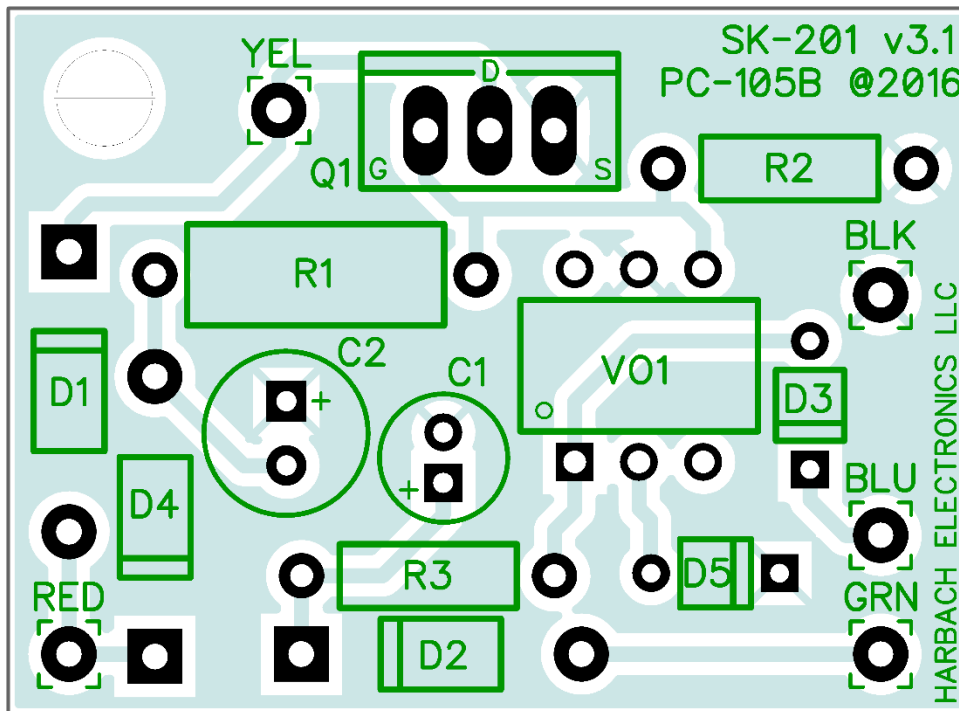

SK-201 BILL OF MATERIALS (BOM)

Verification	Part Number	Quantity	Description	Designation
[]	PCB-105B	1	SK-201 Soft-Key PCB v3.1	N/A
[]	CAP-105	1	100 μ F 10VDC Capacitor	C1
[]	CAP-109	1	1 μ F 160VDC Capacitor	C2
[]	DIO-101	2	1N4005 Diode	D1, D4
[]	DIO-104	1	1N5817 Diode	D2
[]	DIO-105	1	1N60A Diode	D3
[]	DIO-106	1	1N4148 Diode	D5
[]	SMI-103	1	IRF9610 P-Channel MOSFET	Q1
[]	RES-116	1	100K Ω 1/2W Resistor	R1
[]	RES-115	1	10K Ω 1/4W Resistor	R2
[]	RES-114	1	2K Ω 1/4W Resistor	R3
[]	SMI-104	1	4N33 Optocoupler	VO1
[]	LUG-104	1	2-Lug Terminal Strip	N/A
[]	SCR-105	2	#6-32 x 1/4" Steel Machine Screw	N/A
[]	SPA-102	1	#6-32 1/4" x 3/8" Nylon Hex Spacer	N/A
[]	WAS-105	1	#6-32 Lock Washer	N/A
[]	WIR-106	5"	#20 Stranded Black Wire	N/A
[]	WIR-107	9"	#22 Stranded Blue Wire	N/A
[]	WIR-108	7"	#22 Stranded Red Wire	N/A
[]	WIR-109	7"	#22 Stranded Yellow Wire	N/A
[]	WIR-110	8"	#22 Stranded Green Wire	N/A

HARBACH ELECTRONICS, LLC

Jeff Weinberg – W8CQ
 468 County Road 620
 Polk, OH 44866-9711
 (419) 945-2359

<http://www.harbatchelectronics.com>
info@harbatchelectronics.com